

# **SUT-250-SCLCT**

# SUT-250-SCLCT

## Suggested Tools:

(3) Saw Horses

Standard Screwdriver

Phillips Screwdriver

Ratchet with 13/16", 9/16", 3/4" Sockets

Torque Wrench

7/16", 9/16", 3/4" Open End Wrench

Pliers

Wire Cutters

Square

Measuring Tape

Electrical Tape

Spray Lubricant

Utility Knife

(4) Wheel Chocks

Fish Tape (optional for wiring)

## ASSEMBLY REQUIREMENTS

Torque all T-bolt nuts to 35-40 foot-pounds.

Check all lights before towing.

Tire pressure not to exceed recommendation on serial tag.

Re-torque wheel nuts after first 25 miles to 80 ft pounds and periodically thereafter.

Failure to follow the assembly instructions could result in serious injury or death.

Incorrect assembly or modifications to your trailer will void any specific or implied warranty.

For questions or assistance assembling your trailer call 800-282-5042

**UNPACK AND IDENTIFY THE FOLLOWING PARTS**



Front Tongue Section (**Part A**)



Rear Tongue Section (**Part A**)

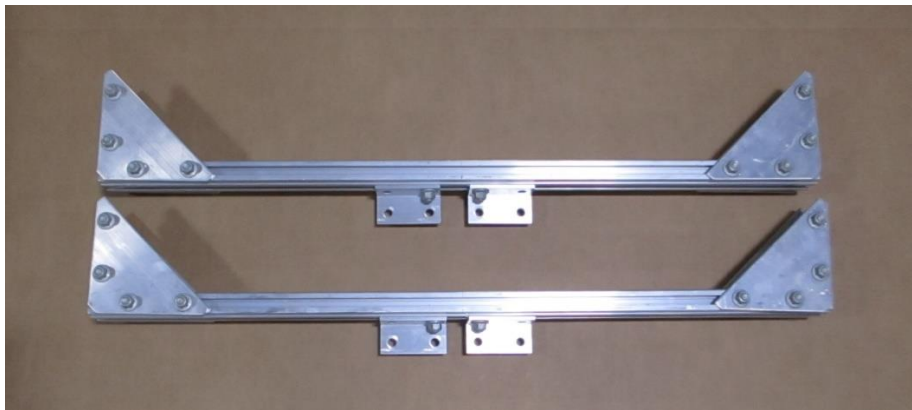

Crossmember Assembly (2) Front and Rear are the same (**Part Q**)



Siderail Assembly (2) Left and Right are the same (**Part R**)



Axle (**Part O**)

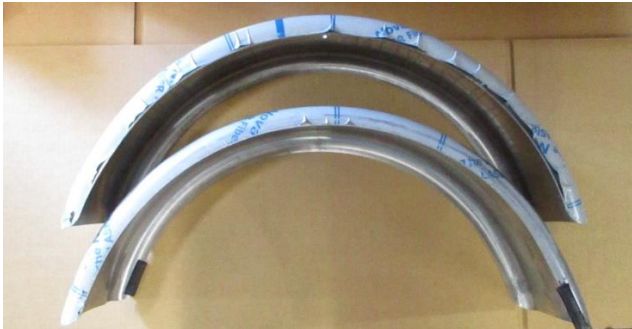

Fenders (2) (**Part S**)



12" Tires (2) (**Part V**)



Inner Fender Braces (2) (**Part F**)



Outer Fender Braces (2) (**Part E**)



Bow Stand (Part D)

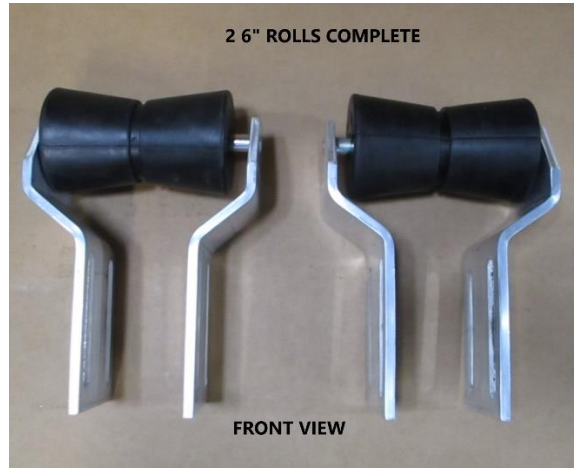

6 Inch Rolls (2) (Part G)



Skid (Part H)



Spare Parts (Part N)



48" Padded Cradles (Part P)



Cradle Brackets (Part L)



Angle Bag (Part M)



Hardware Bag (Part K)



Tail Light Kit (**Part T**) Boxed on left, unboxed on right

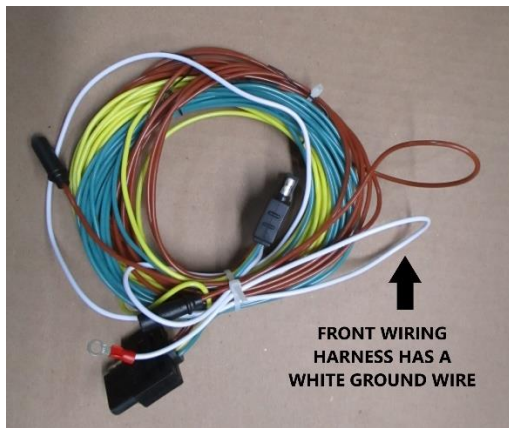

Front Wiring Harness (**Part B**)

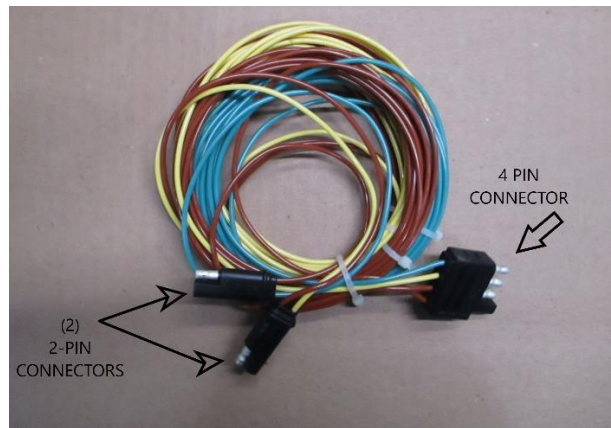

Rear Wiring Harness (**Part C**)



Tail Light Brackets (2) (**Part J**)



Marker Light Bracket (**Part I**)

## TONGUE ASSEMBLY

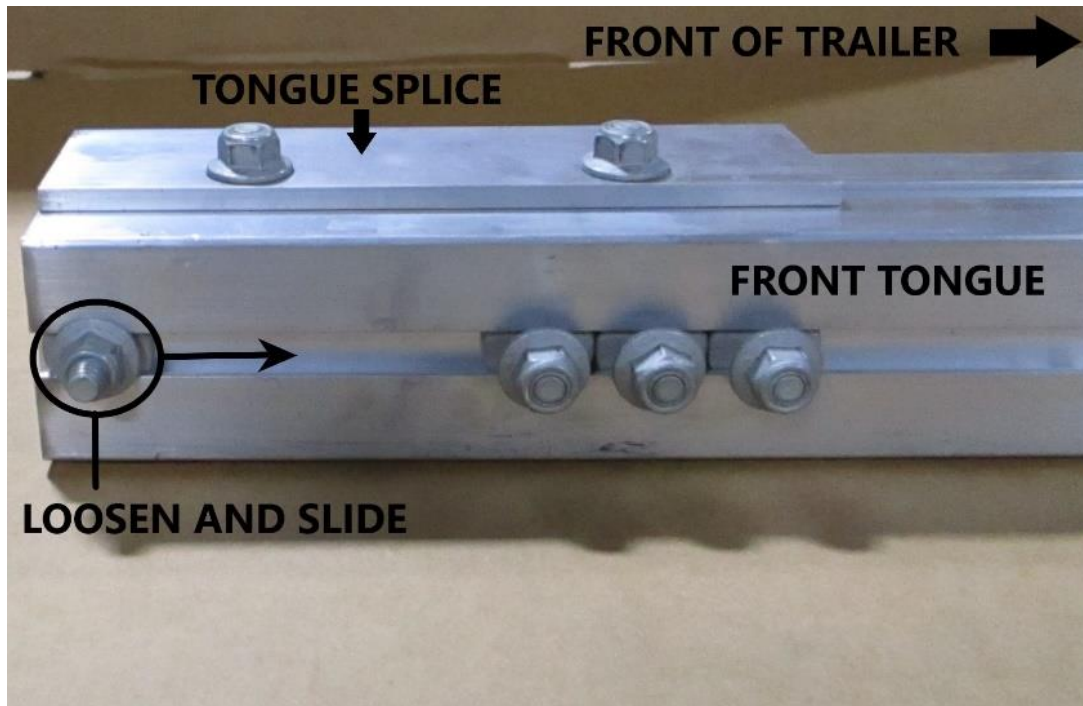

On the back of the front tongue section (**Part A**), loosen the T-bolt and nut on the right-hand side and slide it forward, towards the coupler.

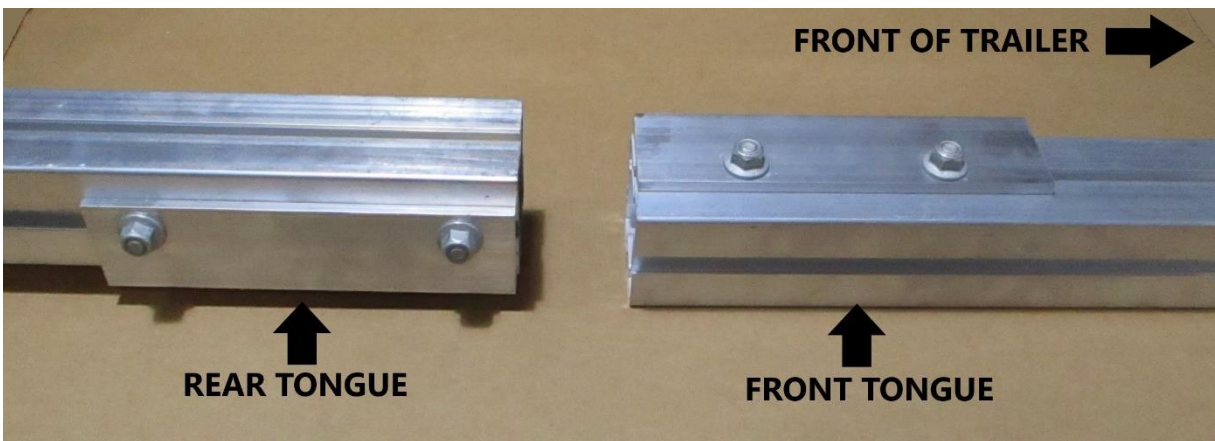

Next, lay the tongue sections (**Part A**) end to end with the splice plates facing each other, as shown above.

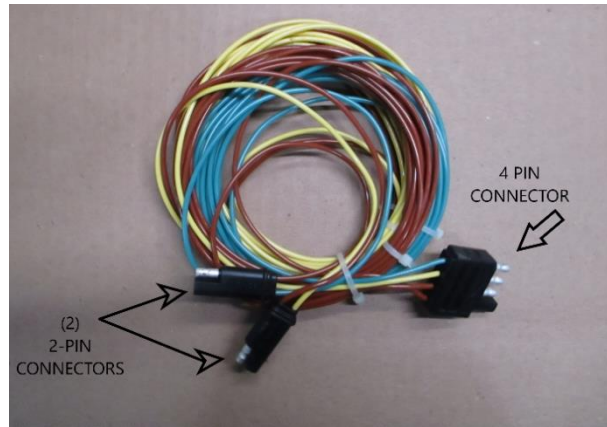
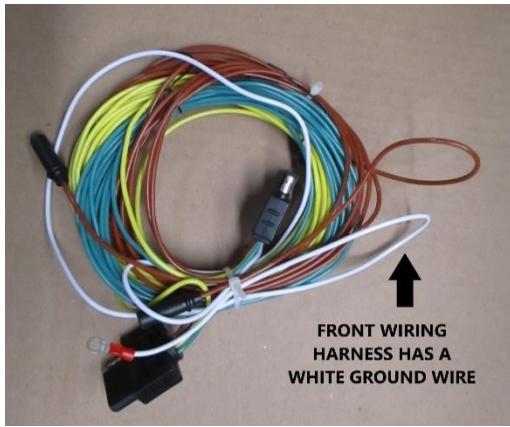

The wiring harness consists of two sections, a Front (**Part B**), and a Rear (**Part C**). Locate the front wiring harness, with the white ground wire, as shown in the left picture above. This end goes at the front of the trailer by the coupler.

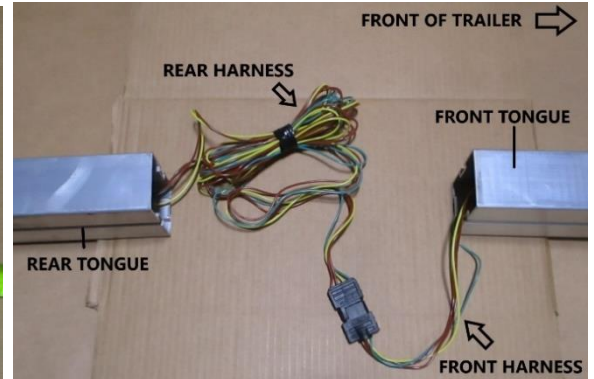
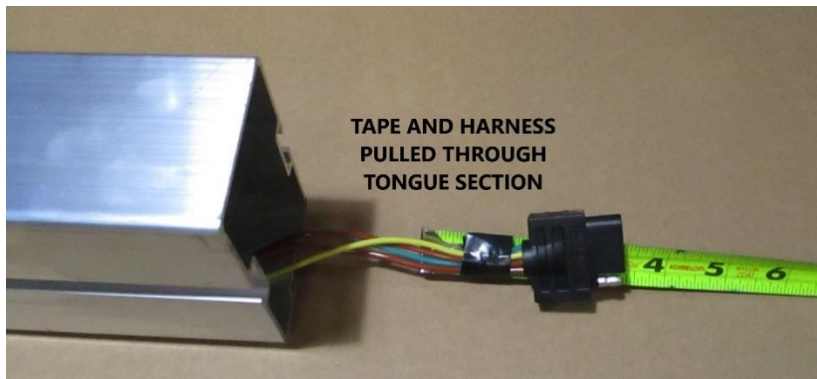
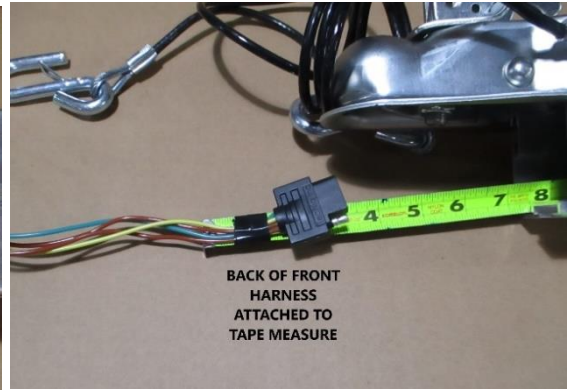
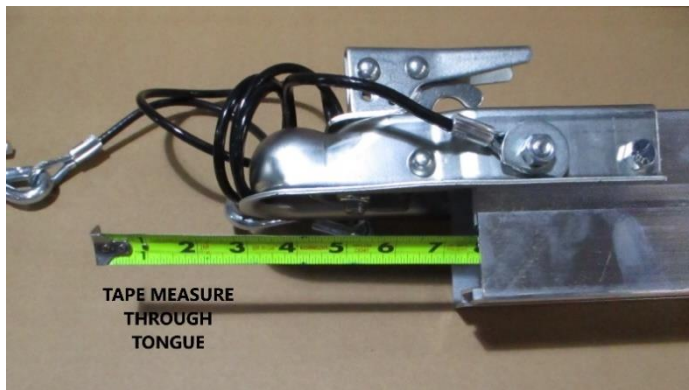

Trailex recommends using a tape measure to pull the wiring harness through the tongue sections. Feed the tape measure through the tongue section and attach the tape measure to the harness with electrical tape. Then, retract the tape measure through the tongue. Repeat for both tongue sections, as shown above. Once the harness is through the tongue sections, plug in the 4-pin connectors. **(This is a universal harness and there will be excess wire)** Pull the rear harness forward leaving enough room at the back to connect the tail lights. Gather any excess wire and tape it, as shown. Then, tuck the wire and 4-pin connectors inside the tongue and slide the sections together.



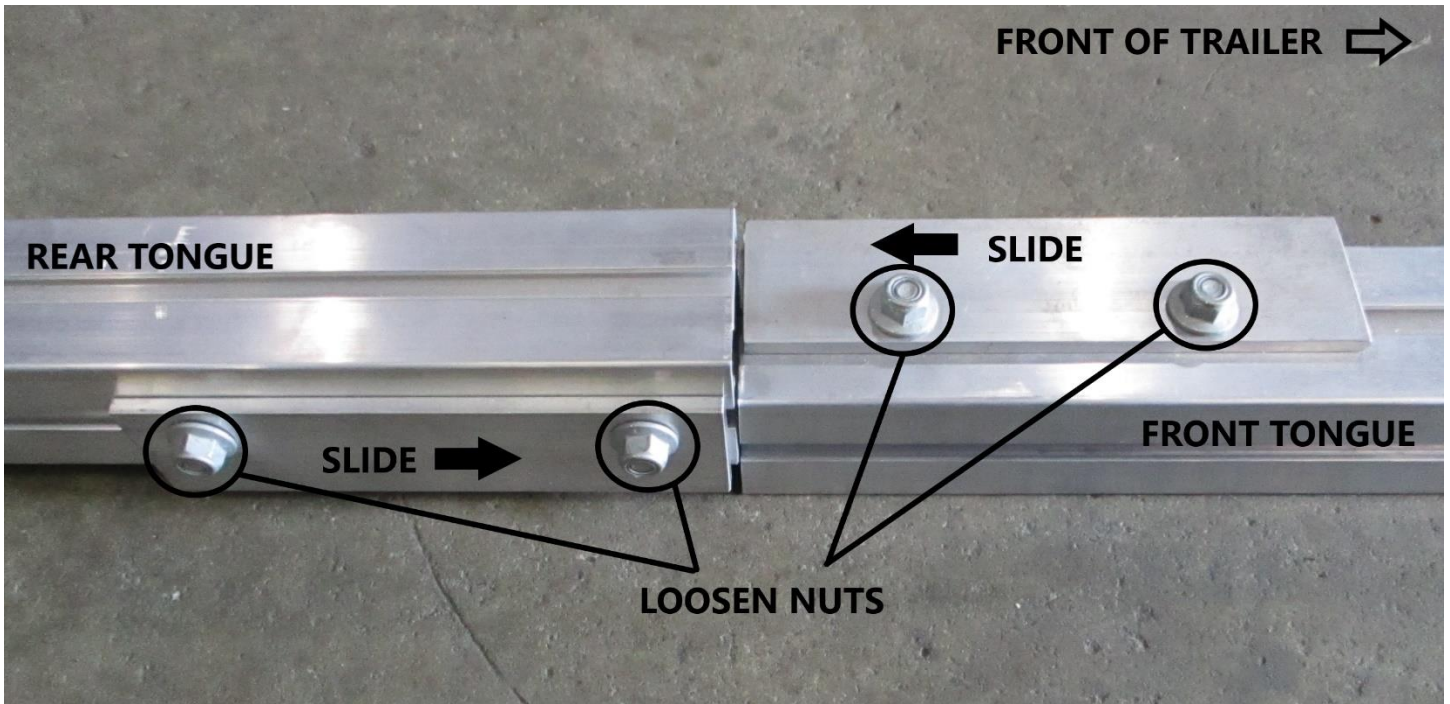

Once the tongue sections are slid together, loosen the nuts holding the splice plates, 8 total, 4 are not seen in this picture. Slide one plate back, and the other forward to join the tongue together.

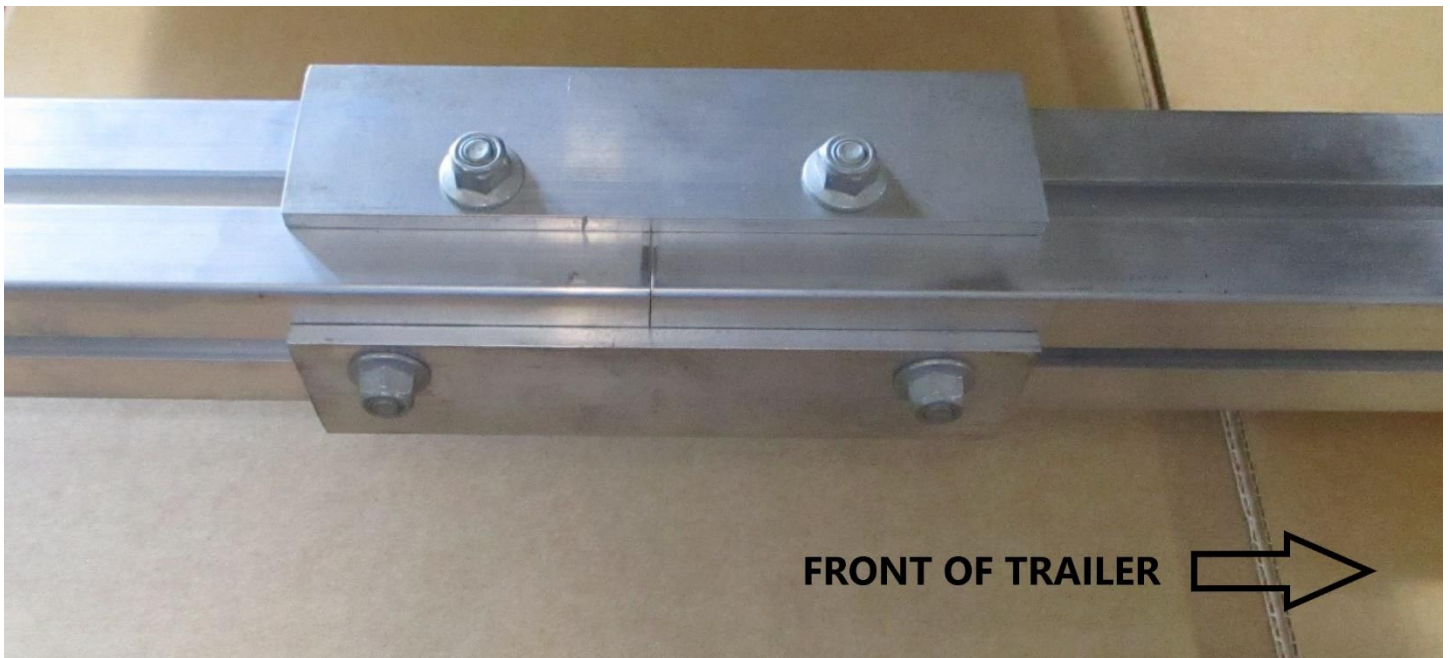

Center the splice plates over where the tongue sections join together and tighten the nuts securely. Then, look down the length of the tongue to make sure it is straight.

## FRAME ASSEMBLY

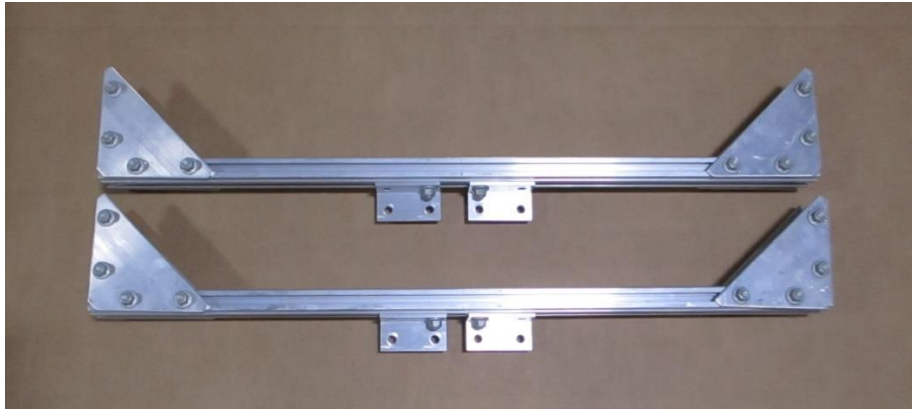

Crossmember Assembly (2) Front and Rear are the same (**Part Q**)



Siderail Assembly (2) Left and Right are the same (**Part R**)

Locate the crossmember and siderail assemblies, there will be 2 of each

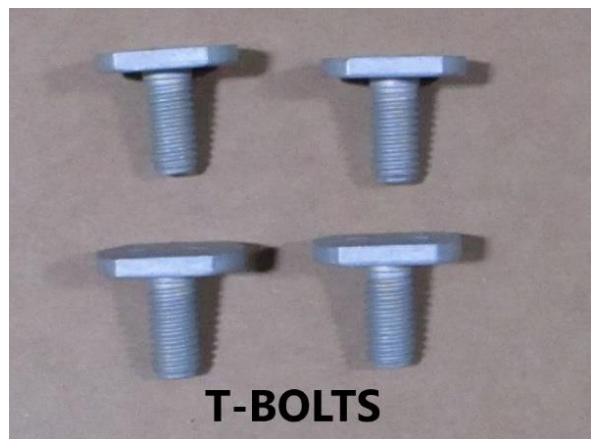

Also, locate the hardware bag (**Part K**), this contains the hardware for mounting the axle, fenders, and other assorted nuts and bolts for the trailer.

Remove 4 T-bolts from the bag.

The frame will be assembled upside down



NOTE: Crossmember shown **UPSIDE DOWN**

Install (1) T-bolt on each side of the angles on the crossmember, as shown above. Repeat for the other crossmember.

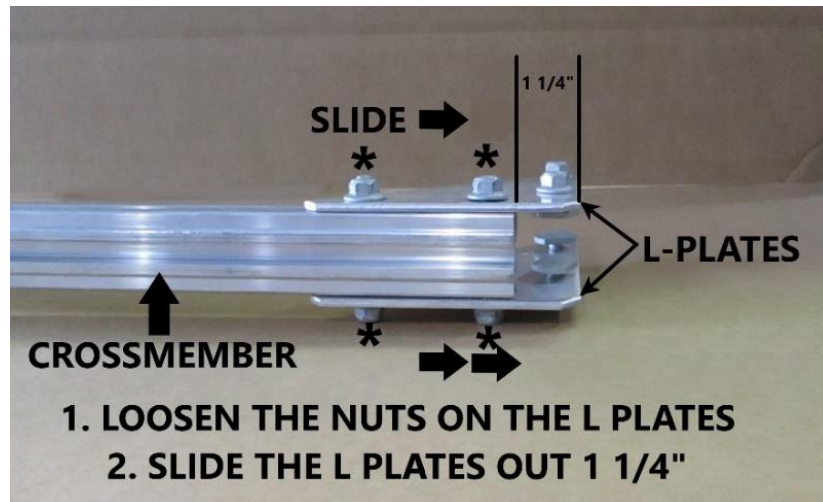

**Loosen the nuts on the L-plates, both top and bottom, and slide them out slightly. The siderail can then slide between them and sit OUTSIDE the crossmember.**

Repeat for the other 3 corners.

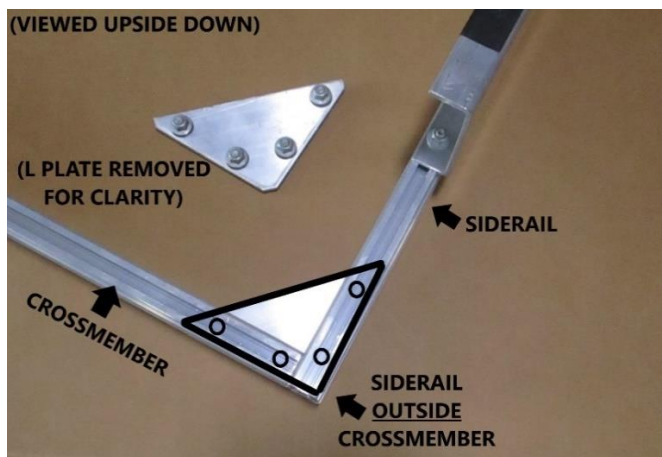

Next, slide the siderail into the L-plates on the **OUTSIDE** and **FLUSH** with the crossmember. If the frame is not assembled this way, the axle will **NOT** fit.

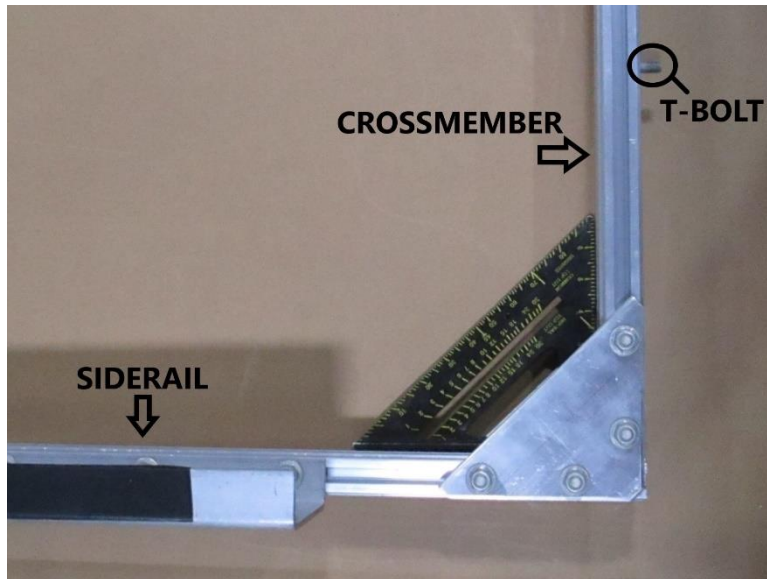

Complete one corner at a time starting with the front crossmember. Square that corner, and tighten the nuts on the top and bottom L-plates before moving on to the other side of the same crossmember. Repeat this process with each corner.

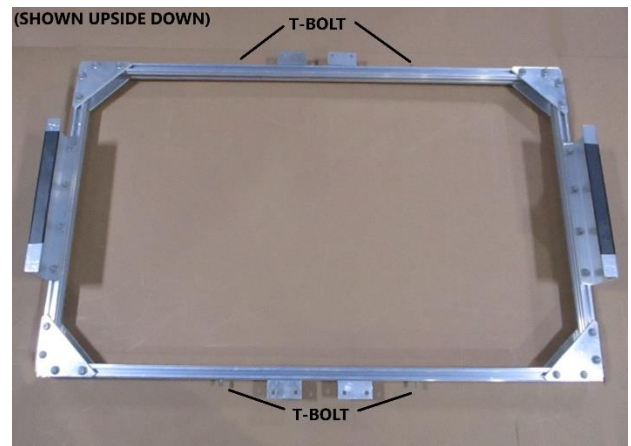
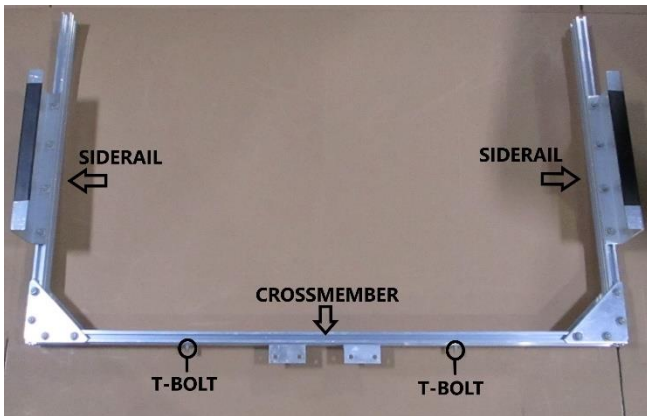

(Upside down view shown)

Both siderails attached to the crossmember.

Completed frame assembly.

Once this is finished, it gets attached to the tongue assembly.

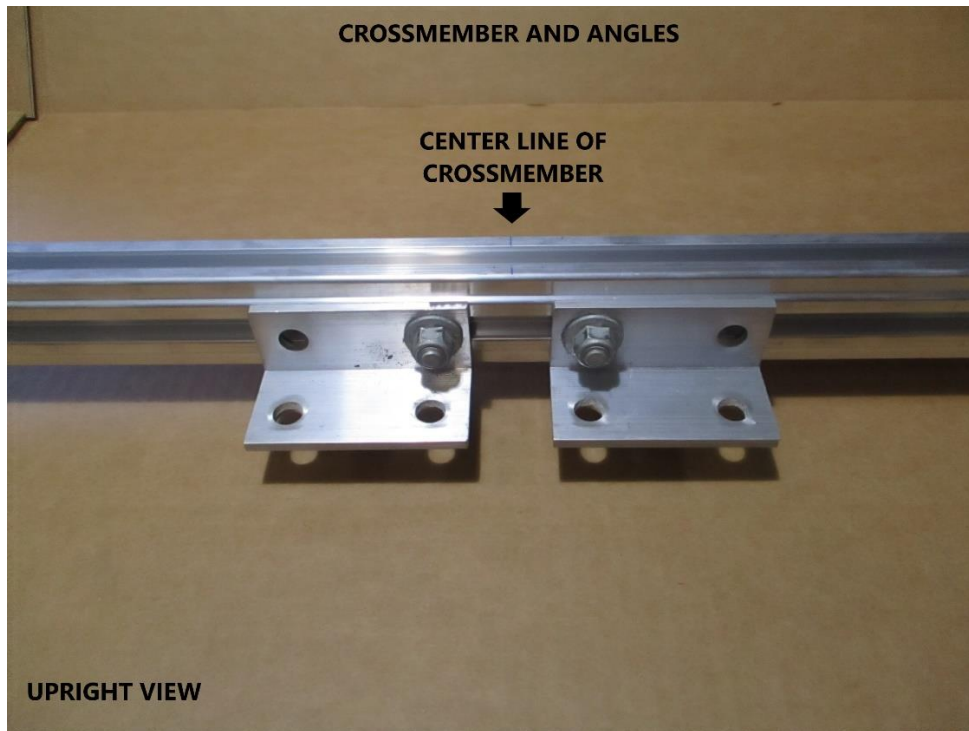

Turn the frame right side up and locate the center line on the top of the crossmember.

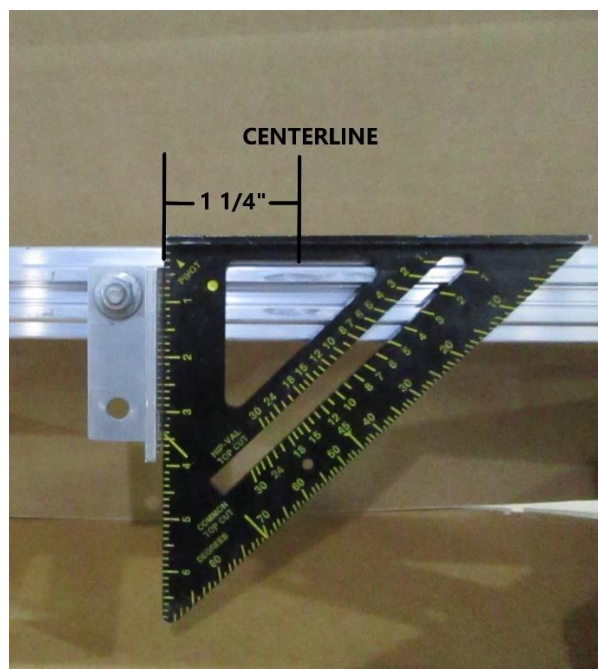

**(Upright View)**

Loosen the nut on the angle and move it 1 1/4" from the center line towards the outside of the frame, then square and tighten. Repeat on the other crossmember. Leave the other angle in the "up" position for ease of assembly on the tongue.

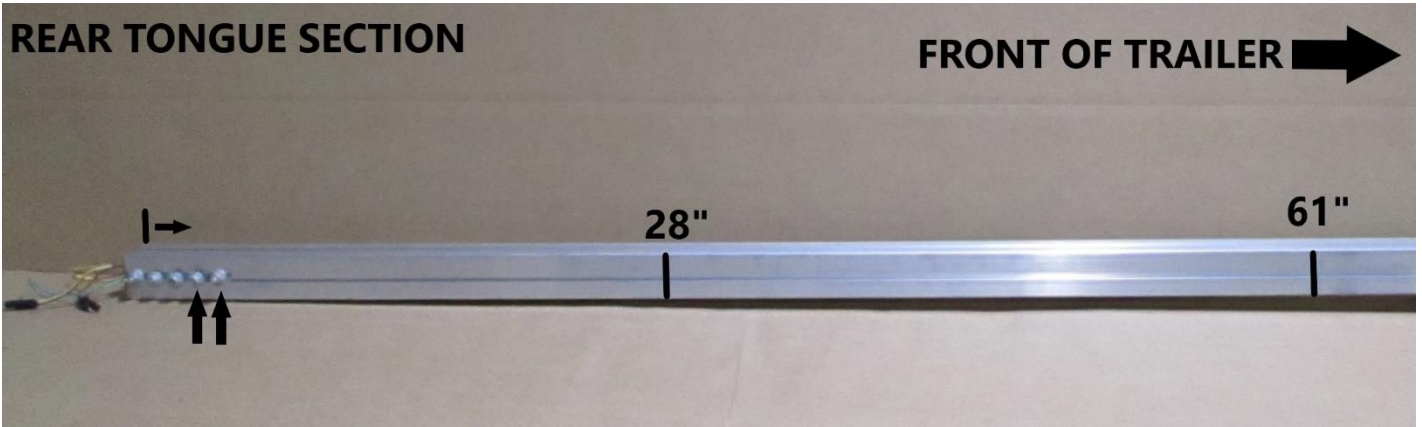

On the rear tongue section, remove the nuts on the 2 T-bolts closest to the front of the trailer and slide them forward to the marks at 28" and 61", as shown in the pic below. Repeat on the other side. These bolts will be used to mount the frame to the tongue assembly.

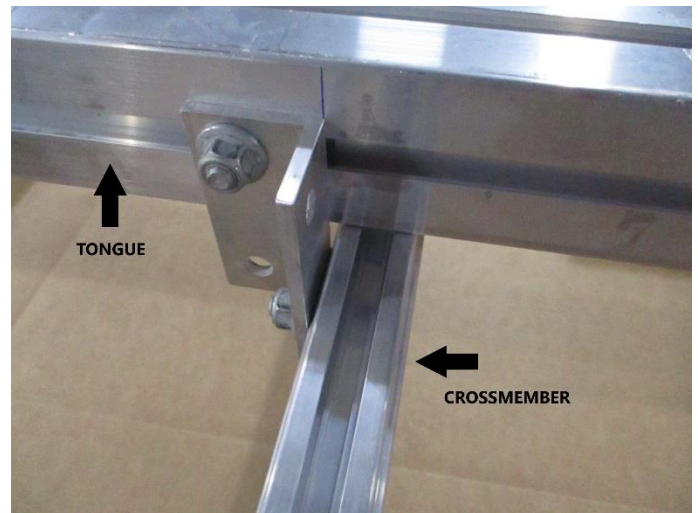
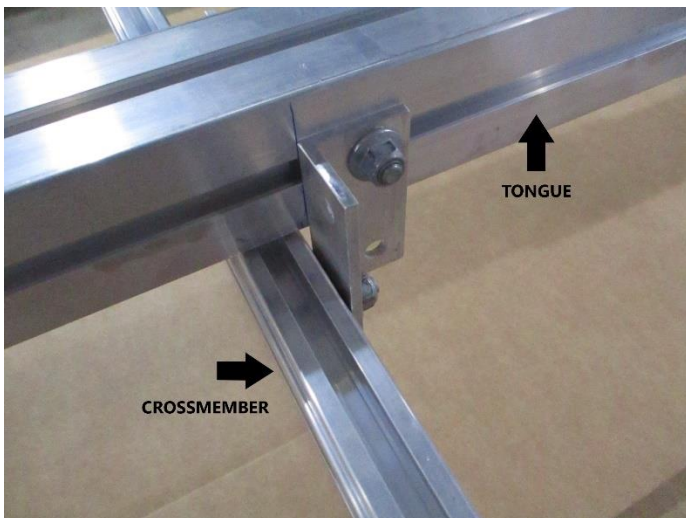

**(Upside down view shown)**

Mount the angles from the previous step on the marks on the tongue, as shown. Repeat for the opposite side of the trailer as well.

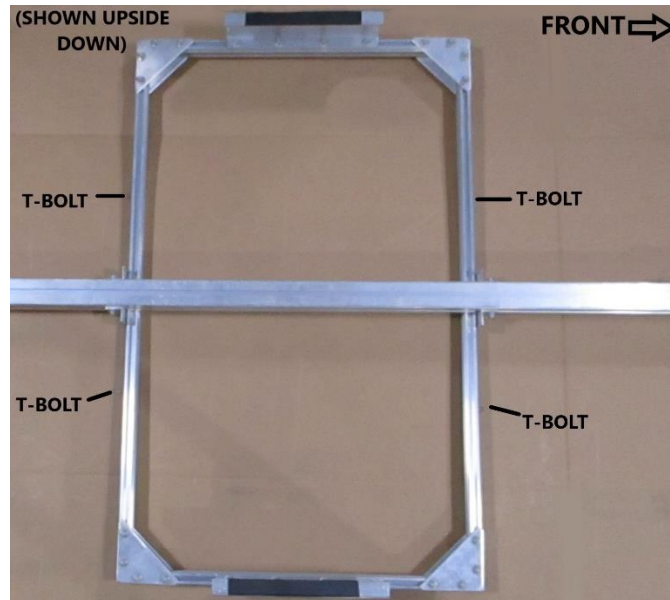

At this point, the trailer should look like this, with the frame mounted and the trailer upside down.



Locate the axle (**Part O**).



Locate the hardware bag (**Part K**)

## AXLE and FENDER INSTALLATION

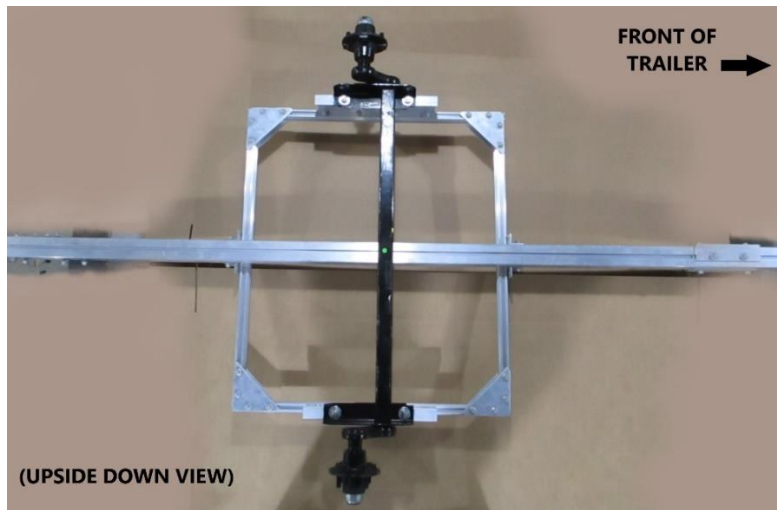

Axle set on frame. Upside down view shown

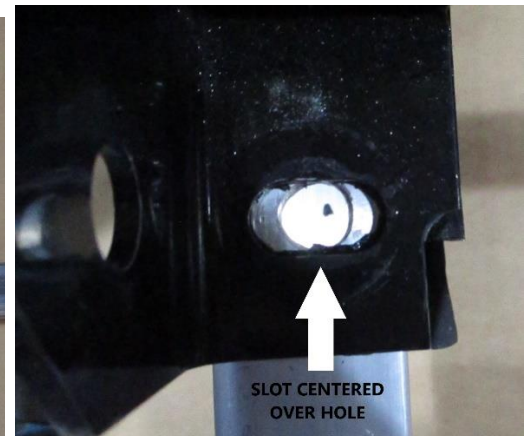

Using a utility knife, remove the tape **only** from the holes in the brackets, as shown. Center the slots on the axle over the holes on the bracket, repeat for all 4 holes.

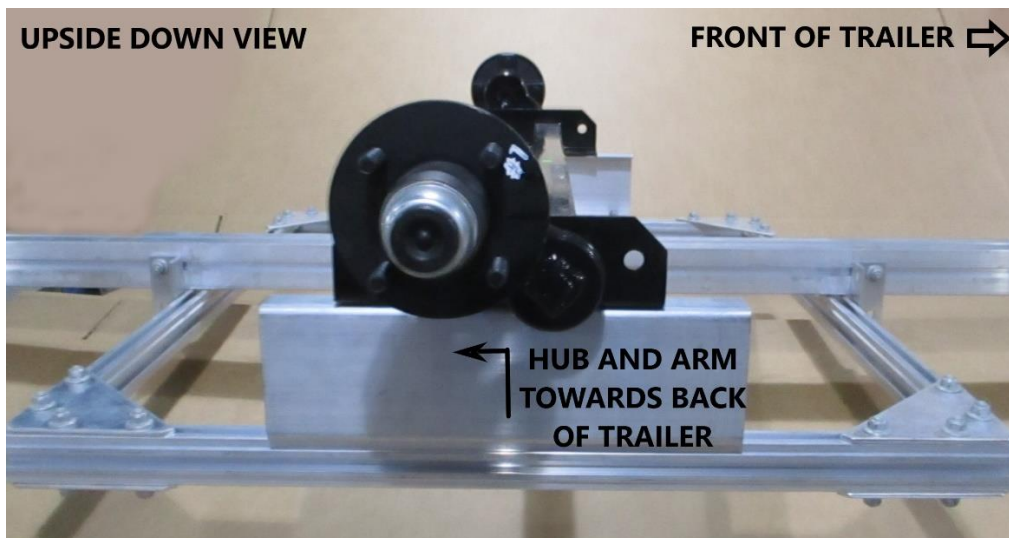

When putting the axle on, make sure that the hub and arm are pointing towards the back of the trailer, as shown in the pic above.



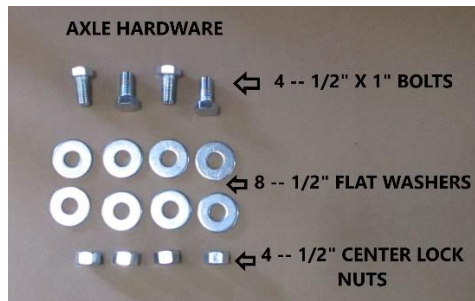

Locate the axle hardware from the hardware bag (**Part K**).

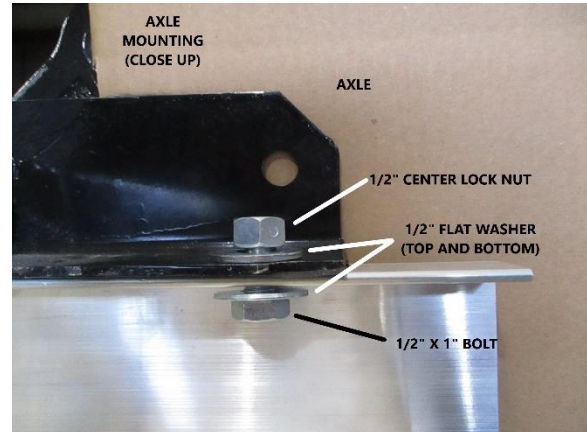
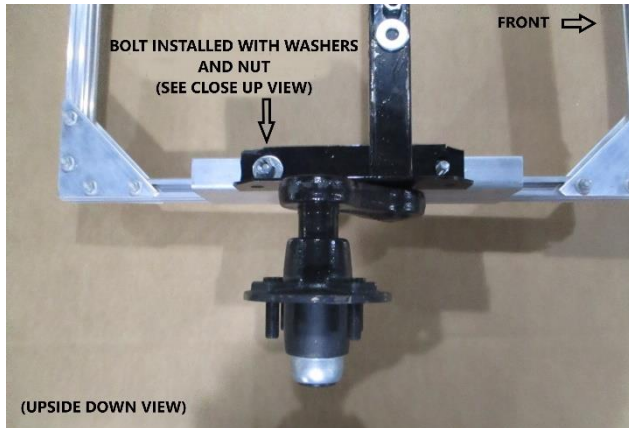

With the axle sitting on the brackets, install the hardware. The bolt goes through from the top of the trailer down with 2 washers and a center lock nut, as shown above.

**Be sure the axle is centered on the brackets before tightening. Tighten in an X-pattern.**

Locate the parts for the fenders:



Inner fender braces (2) (**Part F**)



Outer fender braces (2) (**Part E**)

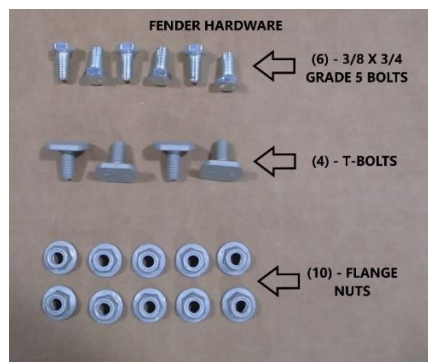

Fender hardware from the hardware bag.

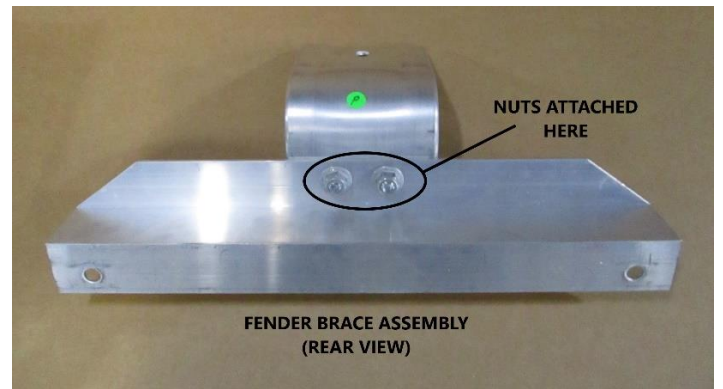
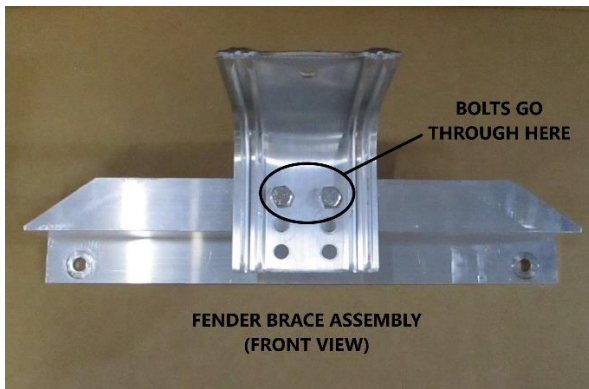

Mount the outer fender brace (**Part E**) to the inner fender brace (**Part F**) using the 3/4" bolts and flange nuts from the hardware bag. Put the bolts through the top holes as shown above.

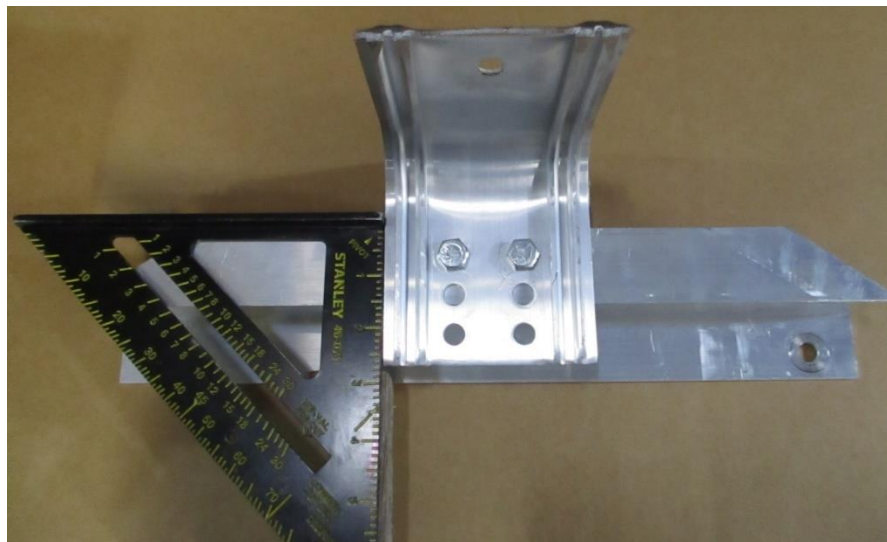

Before installing on the frame, square and tighten the fender braces together.

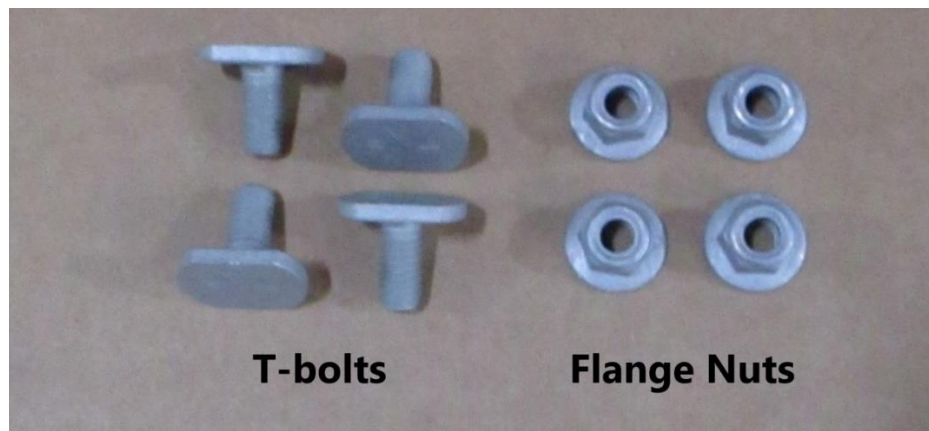

Locate the 4 T-bolts and flange nuts, from the hardware bag, to install the fender braces onto the siderails.

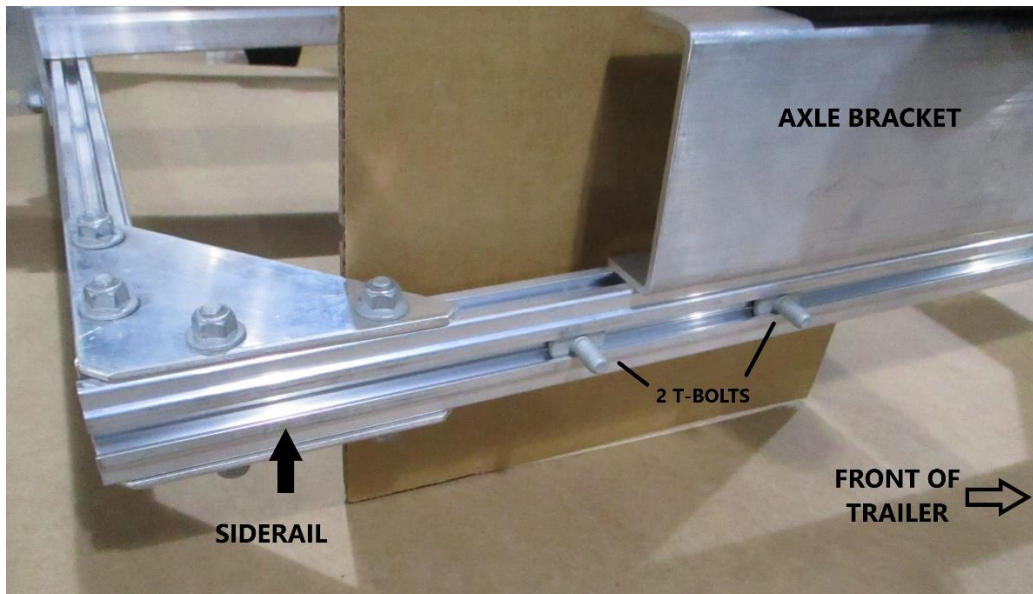

Slide 2 T-bolts into the siderail and attach the fender brace assembly from the previous step.

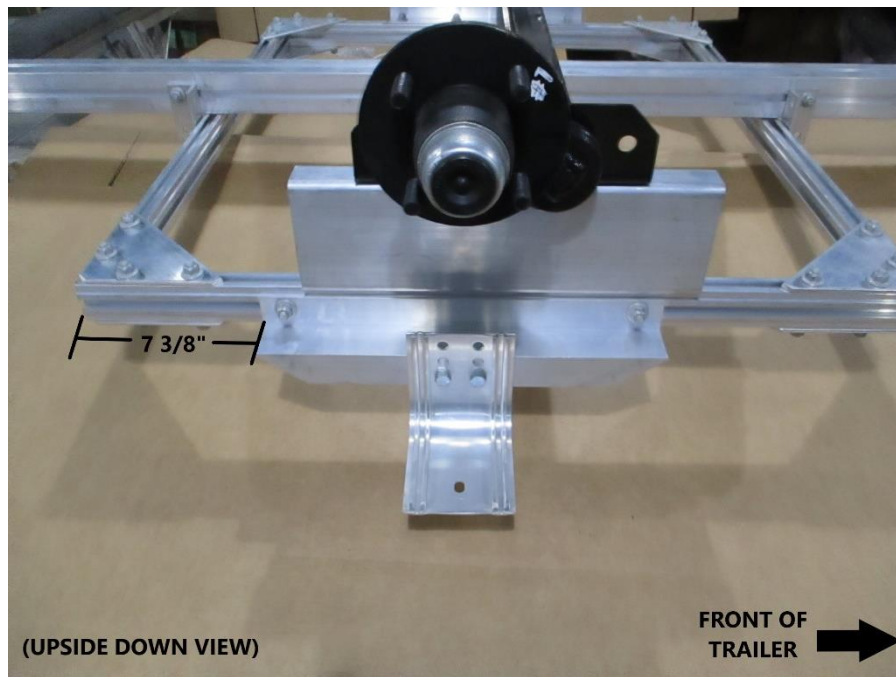

Measure 7 3/8" from the rear of the siderail and mount the fender brace.  
Repeat for the other side.

**NOTE:** The fender braces will be off-center towards the back of the frame, and trailer. This allows the most movement of the tire and axle within the fender.

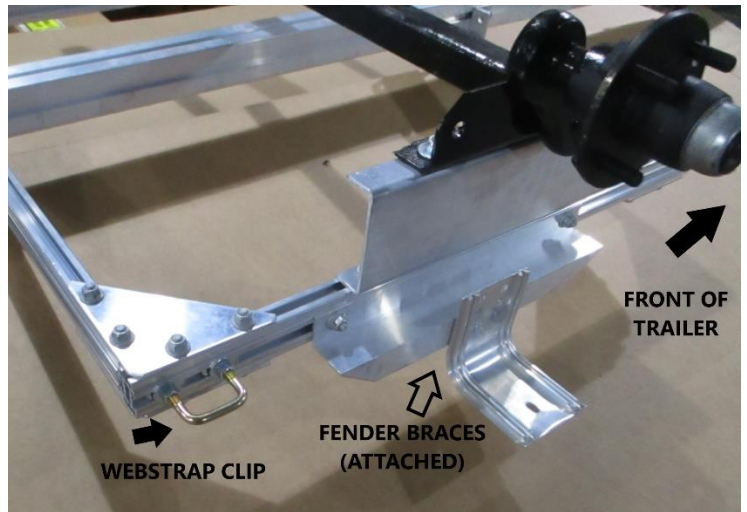

Locate the two webstrap clips from the hardware bag, and slide one on each siderail behind the fender braces and tighten.

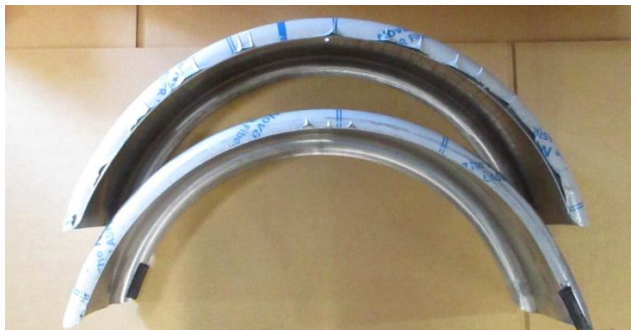

Locate the fenders (**Part S**), and peel the plastic film off before installation.



Locate (2), 3/4" bolts, and 2 flange nuts from the hardware bag. These will be used to attach the fenders to the braces.



Mount the bolt through the fender and brace as shown.

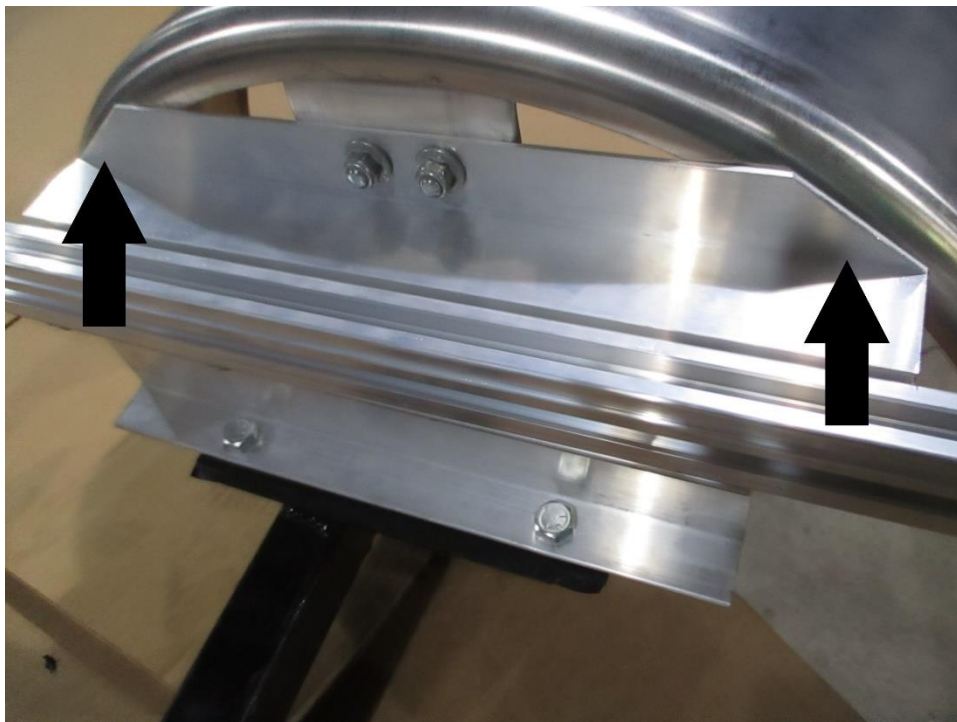

Before tightening, make sure the fender is on the **outside** of outer fender brace. Repeat for the other side.

## WIRING and LIGHTS



Locate the Tail light brackets (**Part J**)

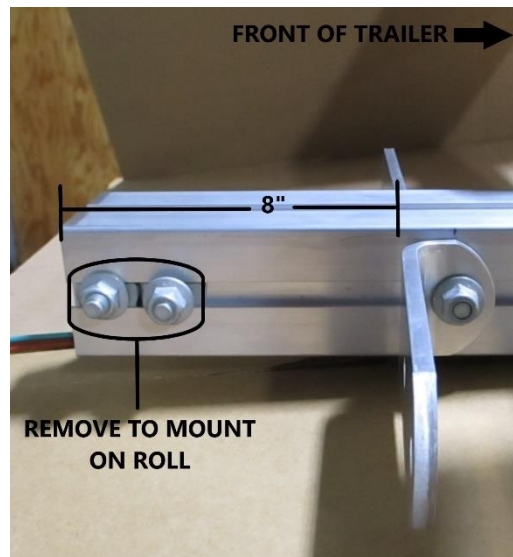

Move the third T-bolt and mount the a tail light bracket (**Part J**) 8" from the back of trailer. Repeat for the other side. Next, loosen and remove the remaining 2 T-bolts and nuts from the end of the tongue and set them aside, they will be used to mount one of the 6" rolls (**Part G**).



Locate the tail light kit box (**Part T**), two tail lights, two marker lights, a license plate bracket, and a bag of electrical parts. NOTE: This is a universal tail light kit, some parts in the bag may not be used on your trailer.

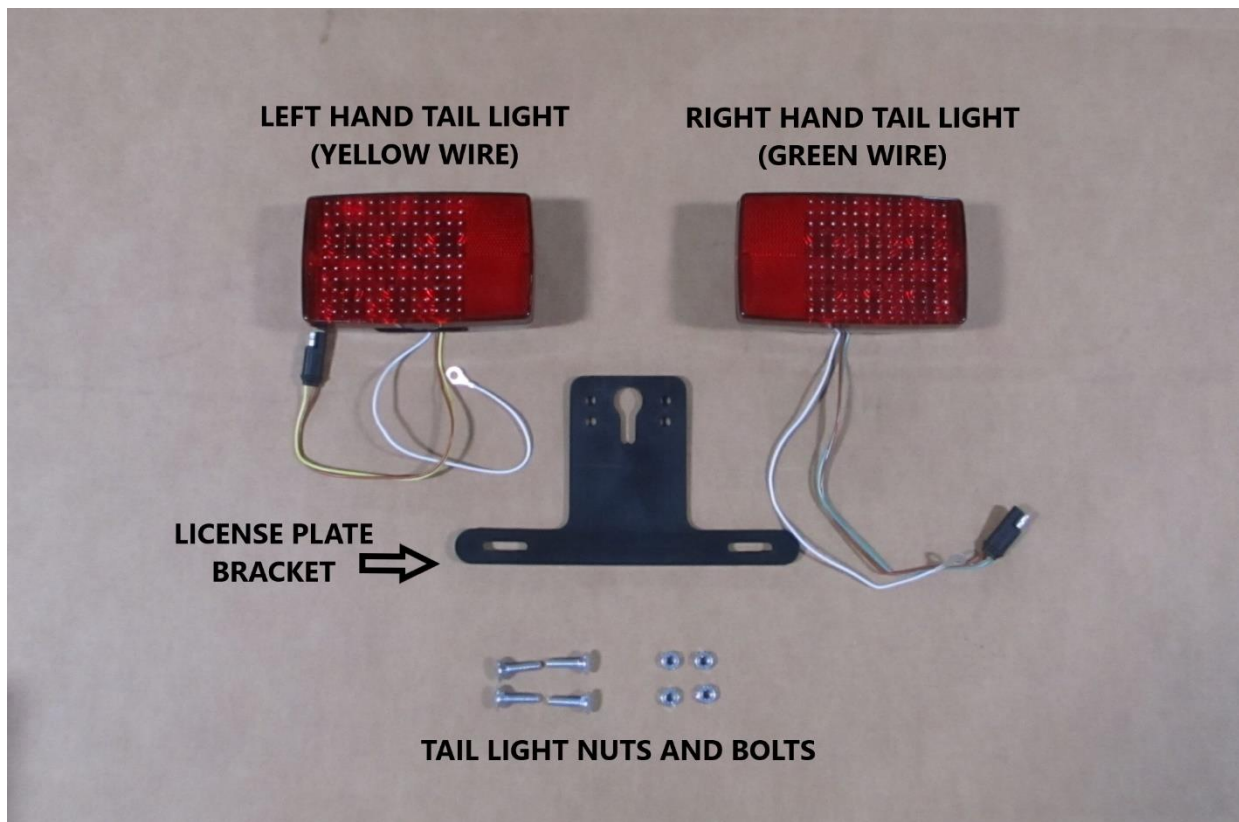

Locate the tail lights, the license plate bracket, and the nuts and bolts from the kit.

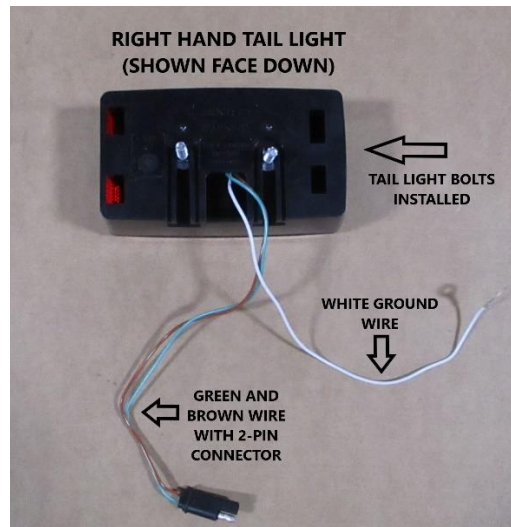

Install the tail light bolts into the back side of the right hand tail light in the slots. Slide them all the way to the top of the slots.

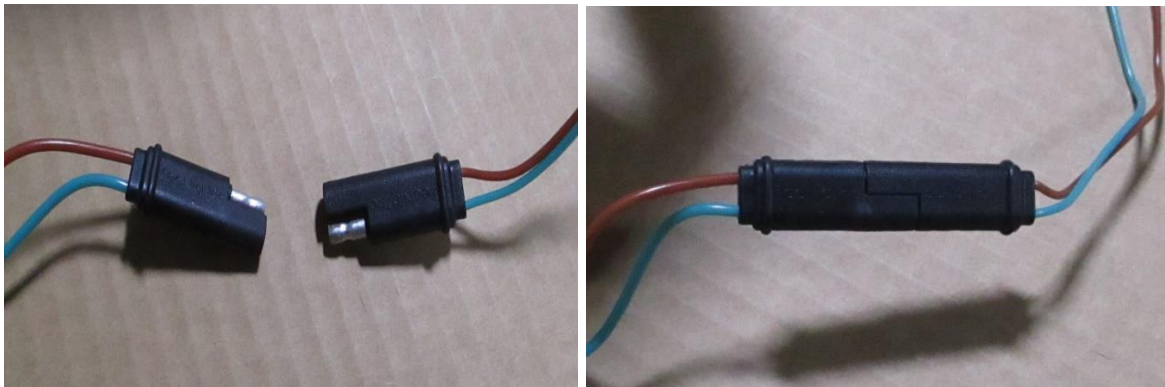

Connect the 2-pin connector for the right hand light with the connector on the wiring harness coming from the rear of the tongue. The green and brown connector from the light will plug into the green and brown connector from the harness.

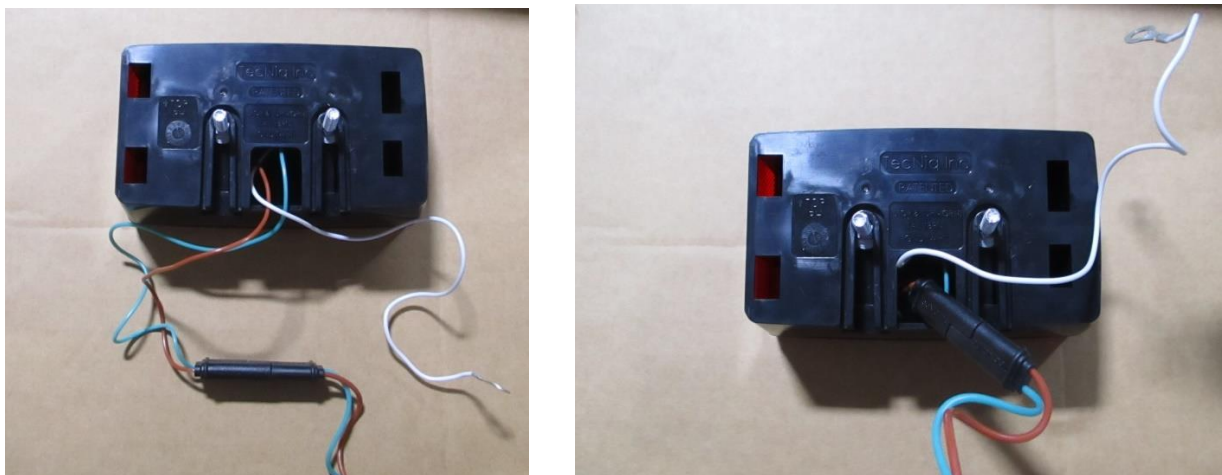

Carefully push the connector and the excess wire into the light before mounting, leave some slack so the wiring harness can go into the tongue once the lights are installed.



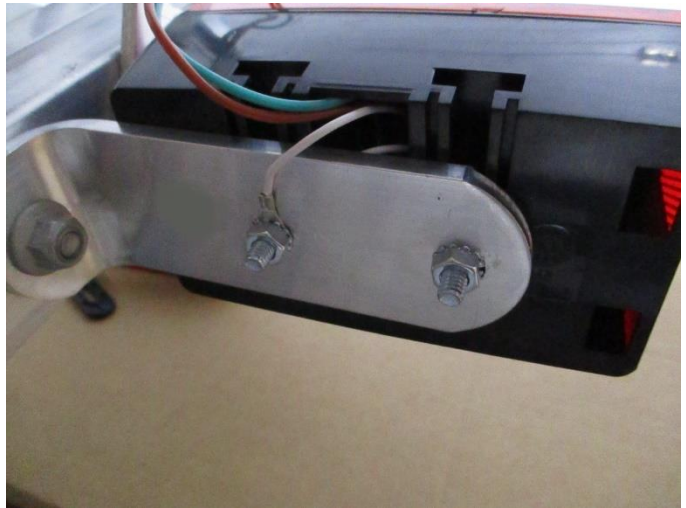
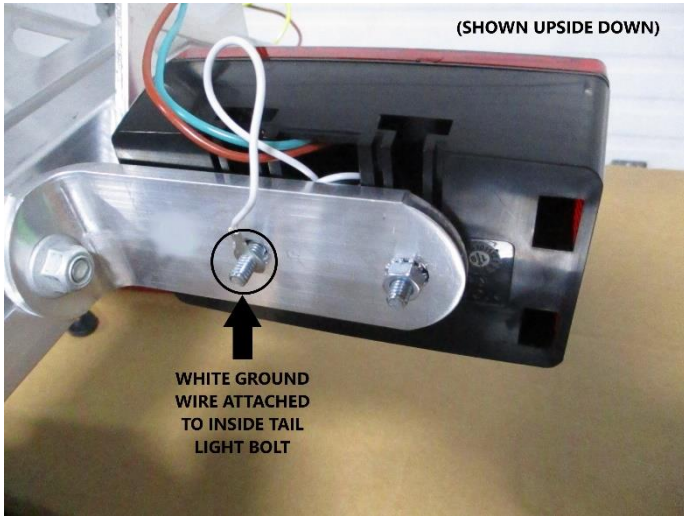

**NOTE:** Trailer shown upside down

Install the tail light onto the bracket and install the white ground wire on the inside bolt, as shown. Install the nuts and tighten.

Repeat for the left hand side.

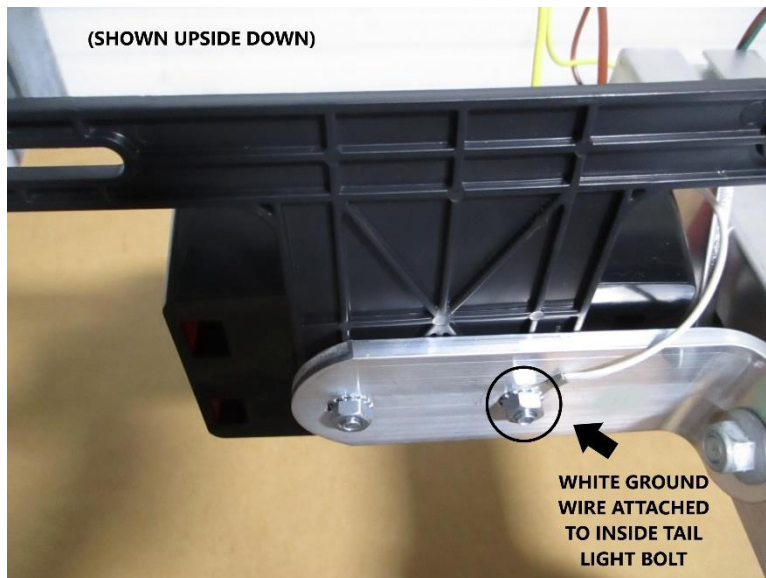
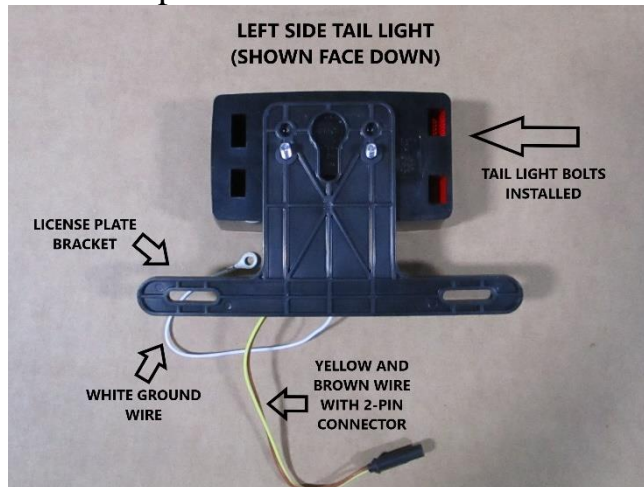

As with the right side, install the white ground wire and tighten the bolts.

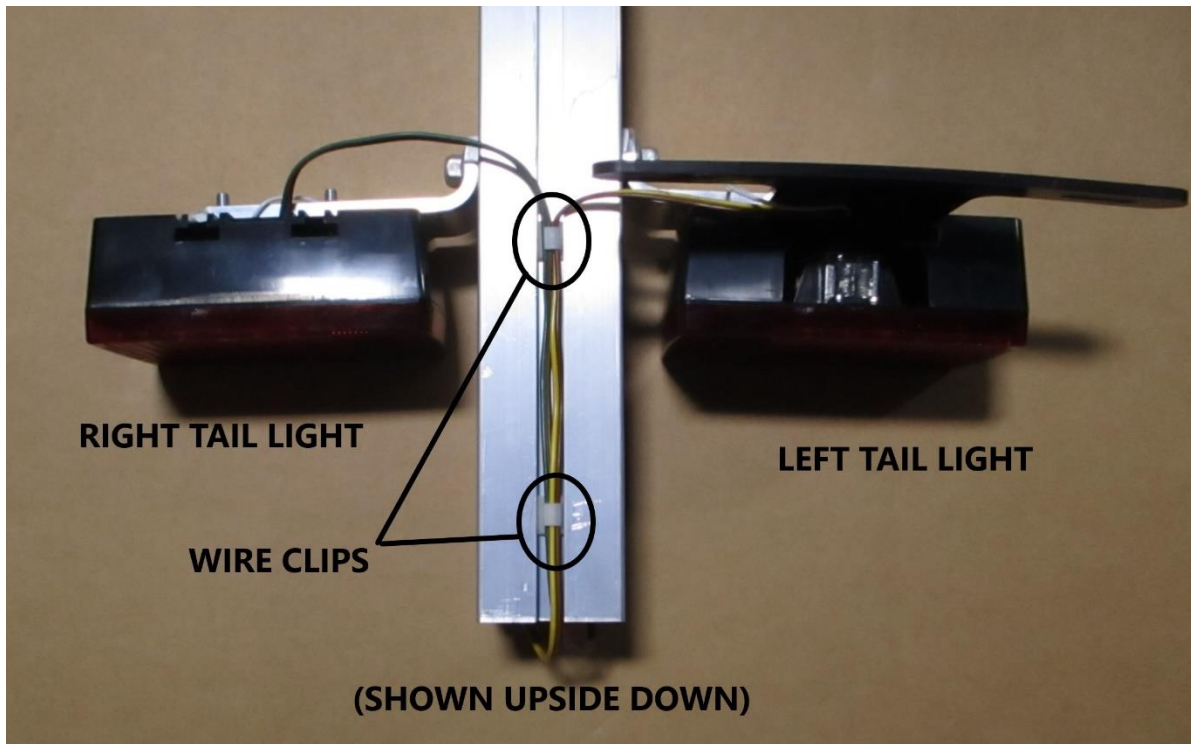

**NOTE:** Trailer shown upside down

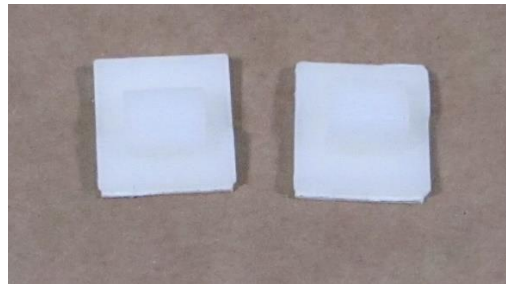

Adhesive wire clips (Colors may vary)

Run the wires from each light to the center of the tongue. Locate 2 wire clips from the tail light kit bag, and install the wires inside the clip. Feed them towards the back of the tongue section. Any extra wire can be tucked inside the tongue.

To continue with the lighting, locate the following parts:

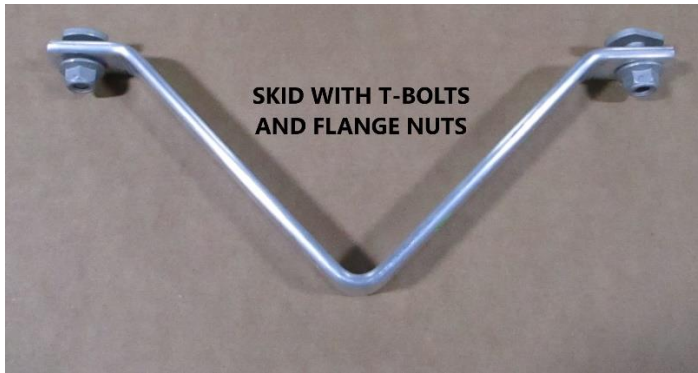

Skid (Part H)



Marker light bracket (Part I)



From the tail light kit, locate the 2 marker lights and 4 screws, from the electrical parts bag.

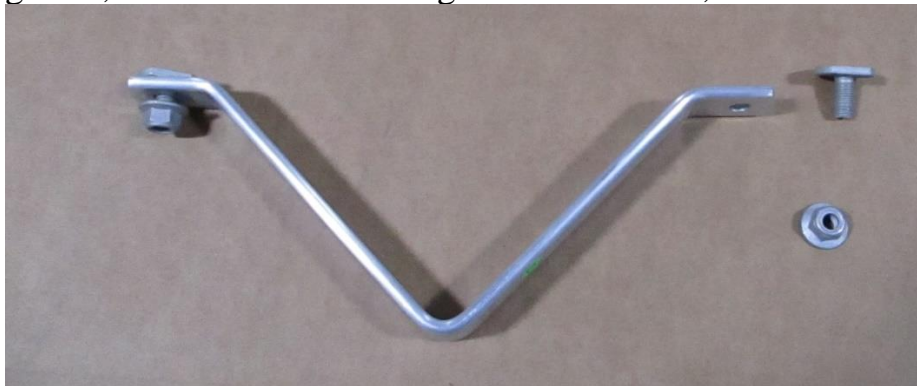

Remove one T-bolt and nut from the skid

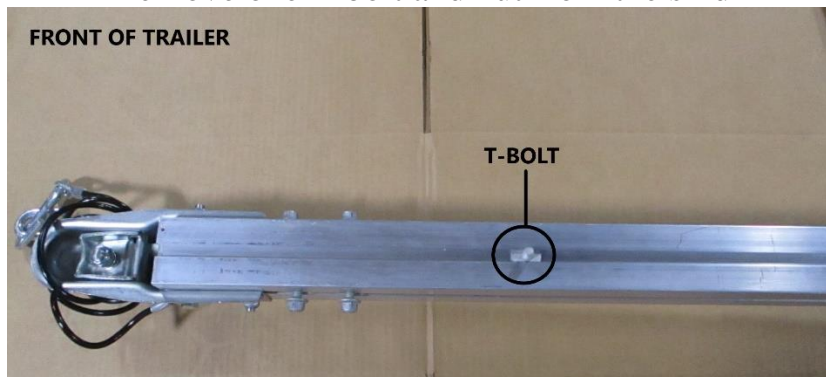

Slide the T-bolt removed from the skid into the slot on the underside of the tongue.

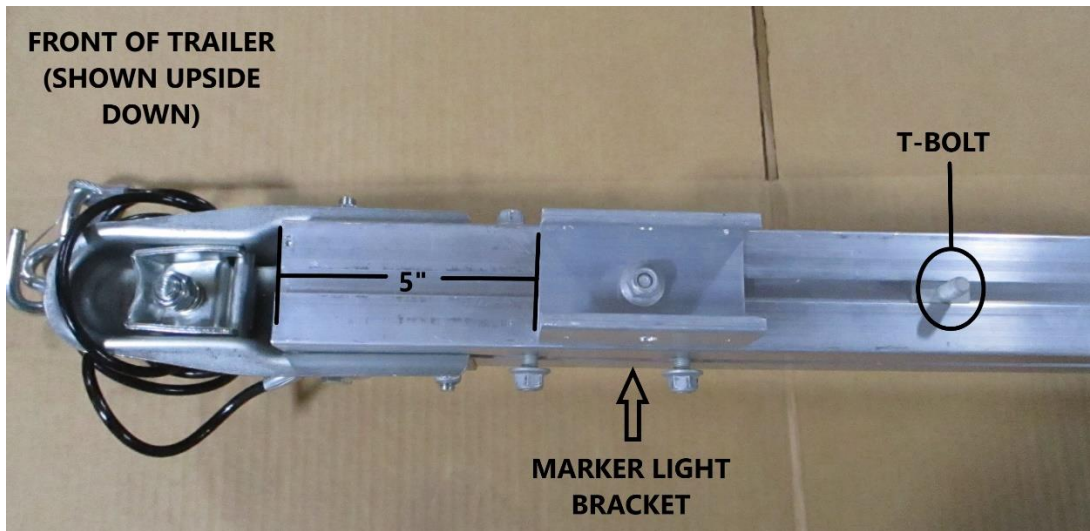

Mark 5" back from the front of the tongue, and install the marker light bracket. **NOTE:** Make sure the T-bolt installed from the previous step is toward the back of the trailer, as shown above.

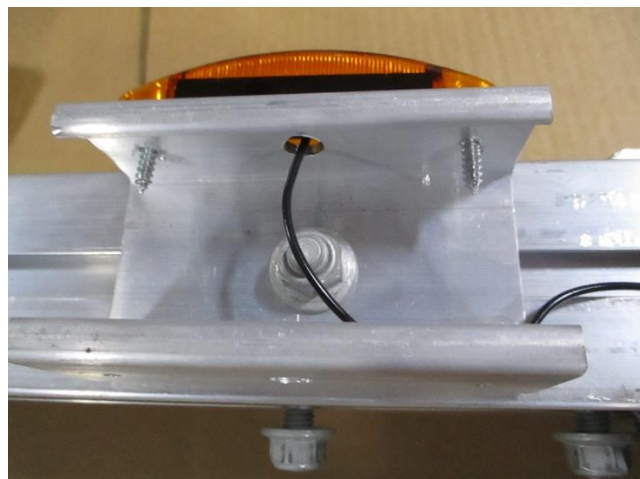

Install the marker light with the screws, as shown. Repeat for the other side.



(Underside view of marker lights installed)

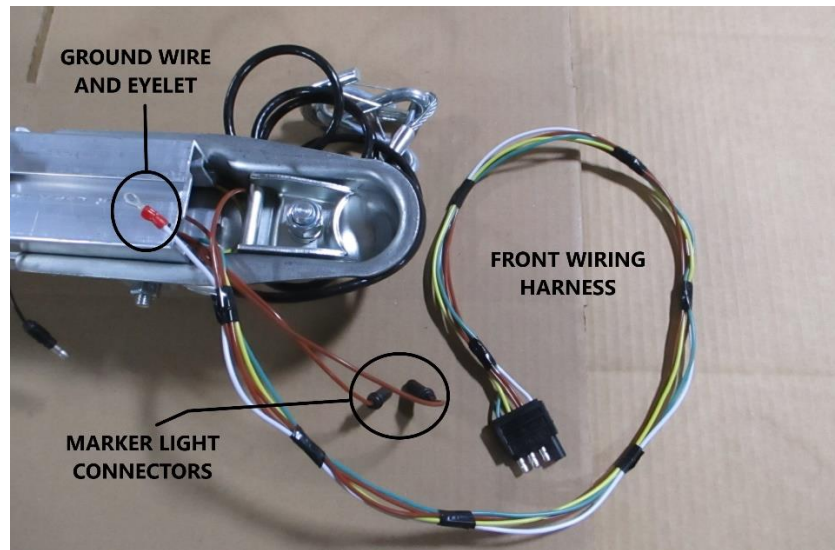

Tape the front wiring harness together from the 4-pin connector on the end along the white ground wire. Space the tape about every 6-8" along the harness. Do not tape the wires for the marker light connectors in with the harness.

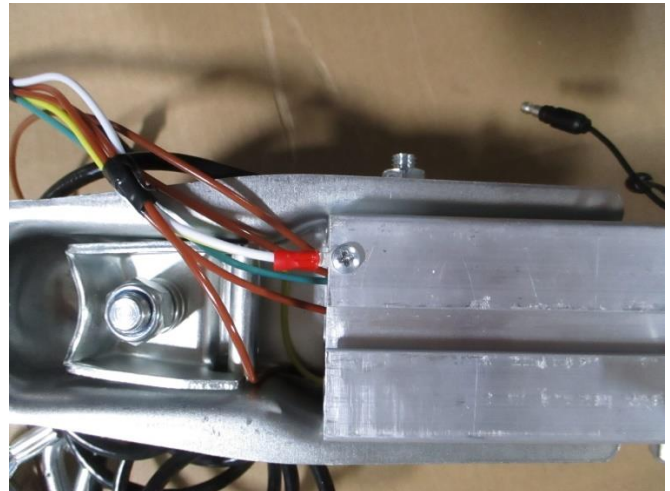

Use one of the remaining screws in the electrical parts bag and install it through the eyelet on the white wire of the harness into the pre-drilled hole for the ground on the tongue.

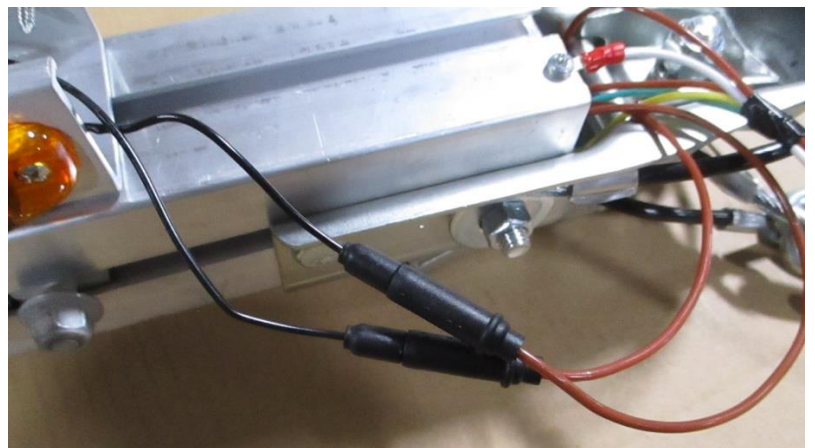
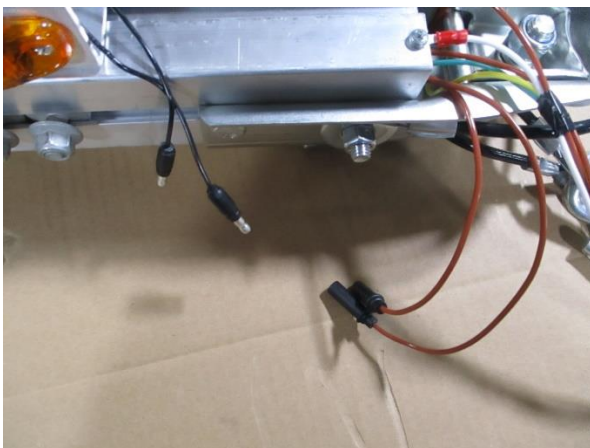

Connect the 1-pin connectors from the marker lights into the 1-pin connectors from the wiring harness.

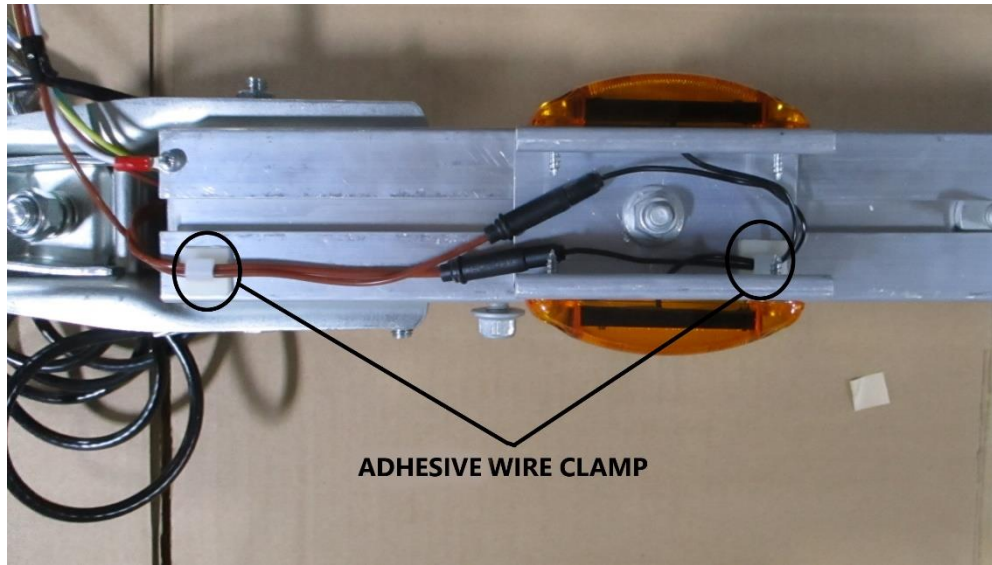

Locate 2 more adhesive wire clamps from the electrical parts bag and install as shown above. **Do not** install them in the groove on the tongue.

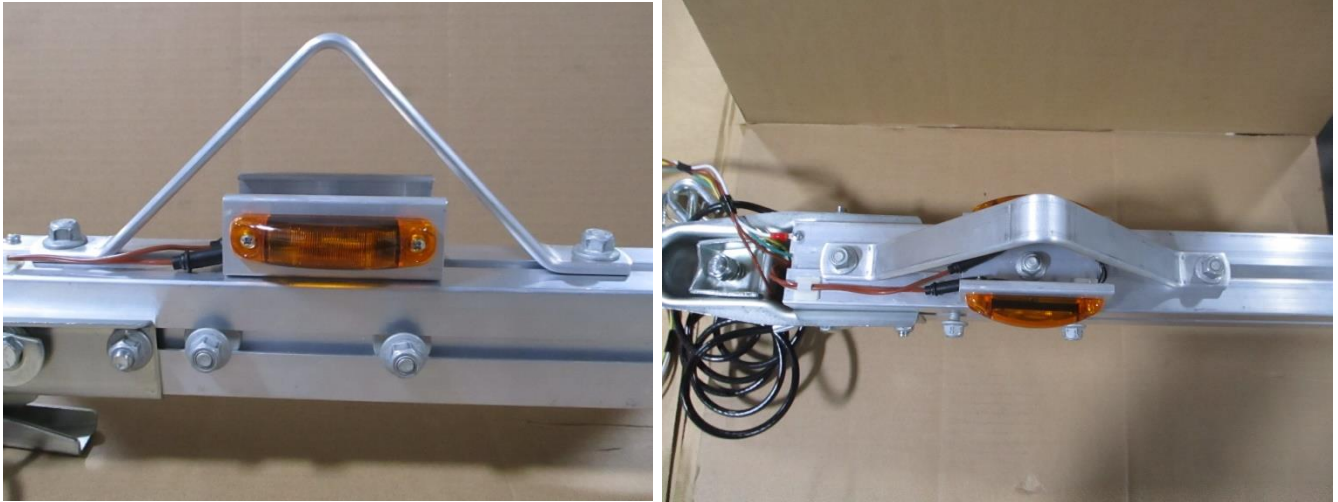

Next, mount the skid onto the tongue. Use the T-bolt installed from the previous step, and the one remaining on the skid. Center it over the marker light bracket, being careful to avoid the wires, and tighten.

## Padded Cradle Installation

### 48" PADDED CRADLES (COMPLETE)



### 48" Padded Cradles (Part P)

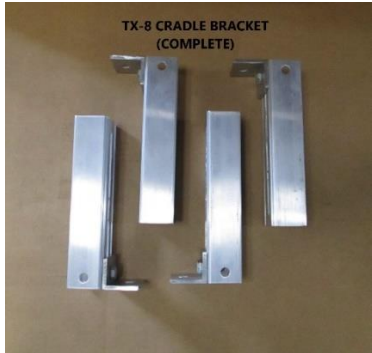

Cradle Brackets (Part L)



Angle Bag (Part M)



Angle Bag contents

Locate the 2 padded cradles (Part P), 4 cradle brackets (Part L), and the angle bag (Part M)

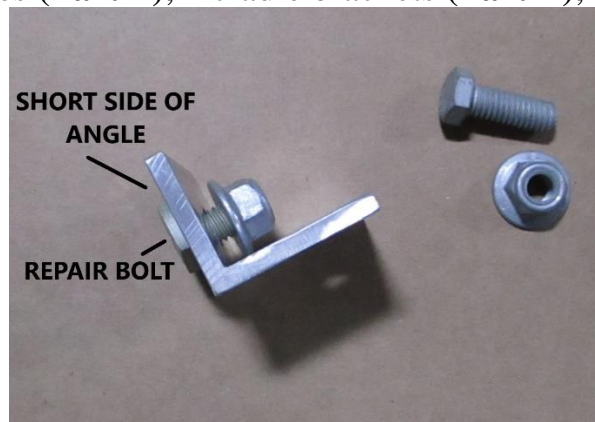

Install a repair bolt into the short side of the angle, as shown in the example piece in the bag.

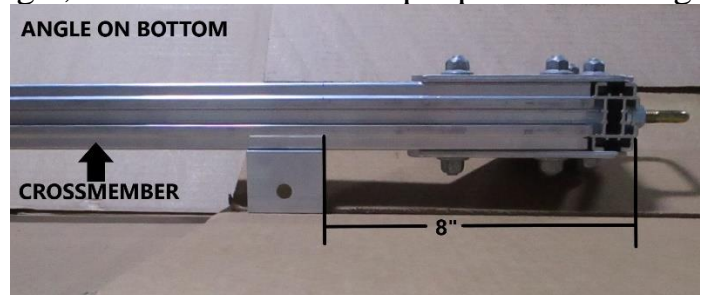
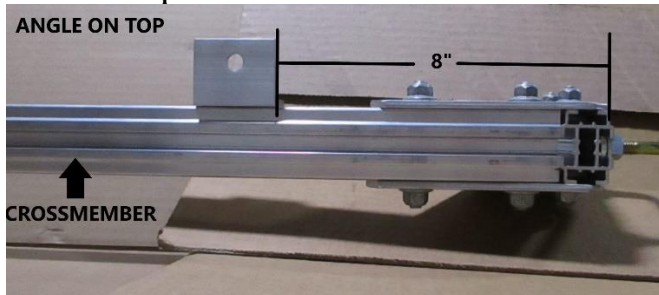

Next, install one of the angles with the repair bolt on either the top or bottom of the crossmember 8" from the end of the trailer. The shape of your boat determines where the angles will be mounted. NOTE: The final position will be determined once the boat is fitted to the trailer.

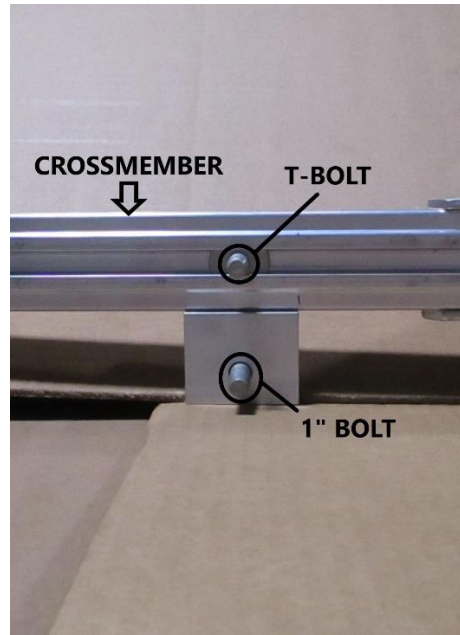

Once the angle is installed onto the bottom or top of the crossmember, slide the T-bolt that was previously installed in the crossmember over and align it with the hole in the angle. Install a 1” bolt into the hole in the angle.

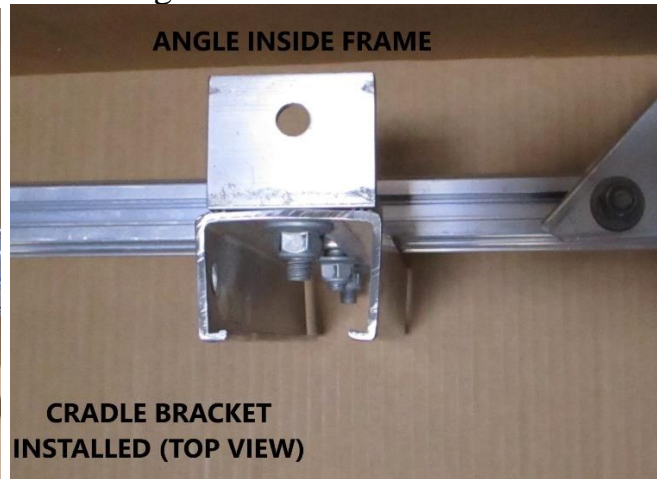
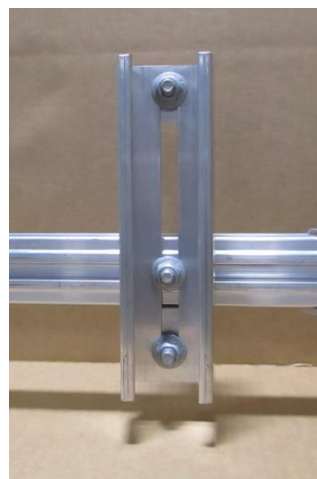

Locate a cradle bracket (**Part L**) install and square, as shown above. **NOTE:** The angle mounted on the cradle bracket will be pointing inside the frame. Repeat for the other 3 cradle brackets. **NOTE:** Final position and height will be determined when the boat is fitted to the trailer.



Remove the lockwashers and nuts from the bottom of the padded cradles.



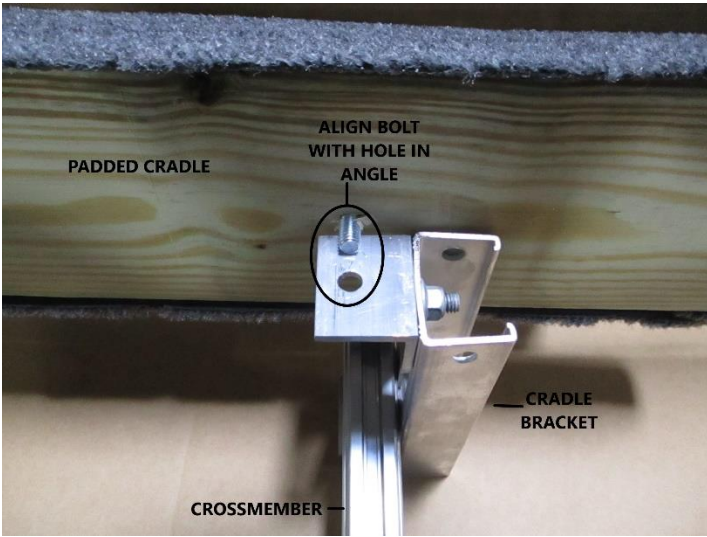

Align the bolt in the padded cradle with the hole in the angle on the cradle bracket. Install the padded cradle, then re-install the lock washer and nut and tighten. Do **NOT** overtighten. Repeat for the other side. **NOTE:** The final position will be determined when the boat is fitted to the trailer.

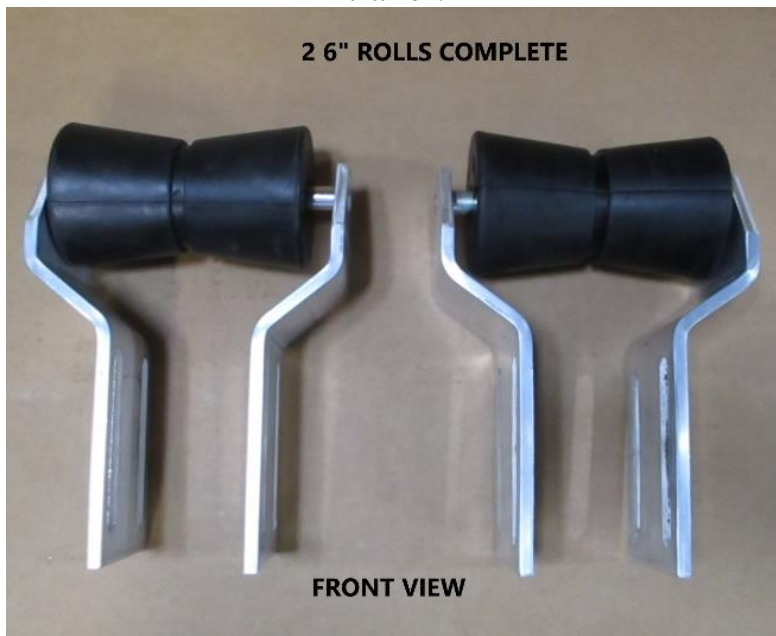

Locate the (2) 6" rolls (**Part G**)

## Rear Roll Installation

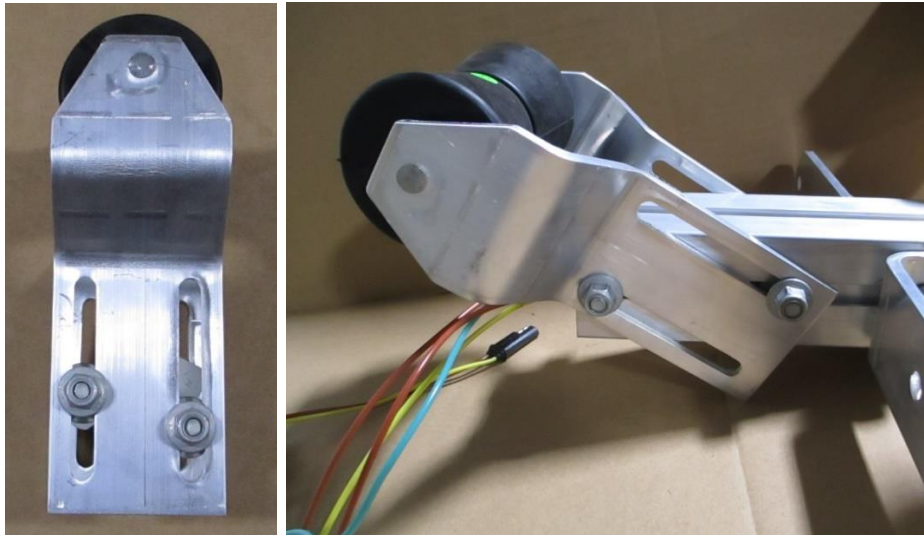

With the T-bolts removed from the tongue when installing the lights, install one T-bolt into each slot of the 6 inch roll, as shown above. Then, slide it onto the tongue and tighten as shown. (Lights removed for clarity) **NOTE:** The final position of this roller is such that it never touches the hull during transport, only during launch and retrieval.

## Front Roll Installation

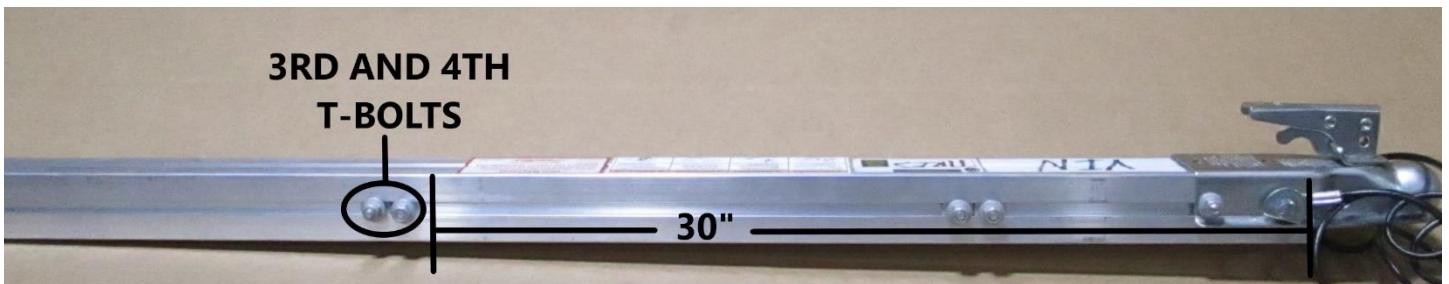

Measure 30" back from the front of the trailer. Remove the nuts from the third and fourth T-bolts on both sides of the tongue.

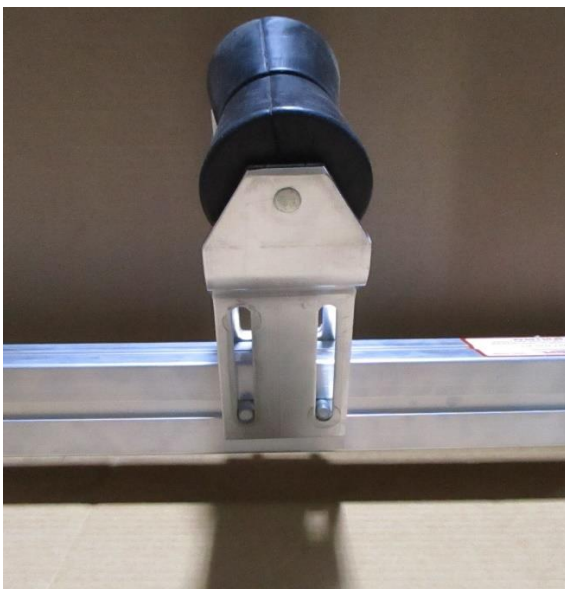

To install the roll, tilt and position it over the T-bolts on one side of the tongue. Gradually, and carefully, pull the opposite side of the bracket over the tongue section and T-bolts.

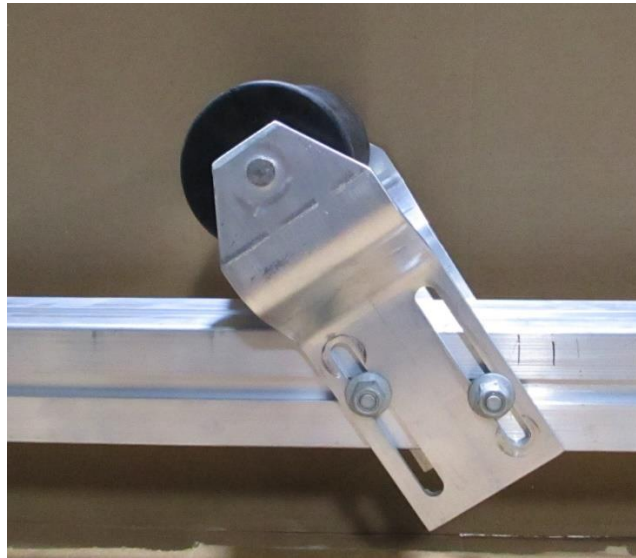

Once installed, tighten the nuts on both sides. NOTE: Final position of this roll will be determined once the boat is fitted to the trailer.

### **Bow Stand Assembly**



Locate the bow stand (**Part D**) NOTE: The bow stand handles are located on the outside of the roll for shipping purposes only. They will be removed and installed on the inside.

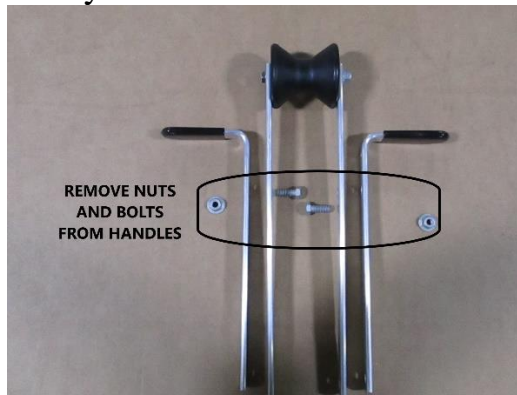

Remove the nuts and bolts, and install the handles on the inside of the bow stand.



It should now look like this.

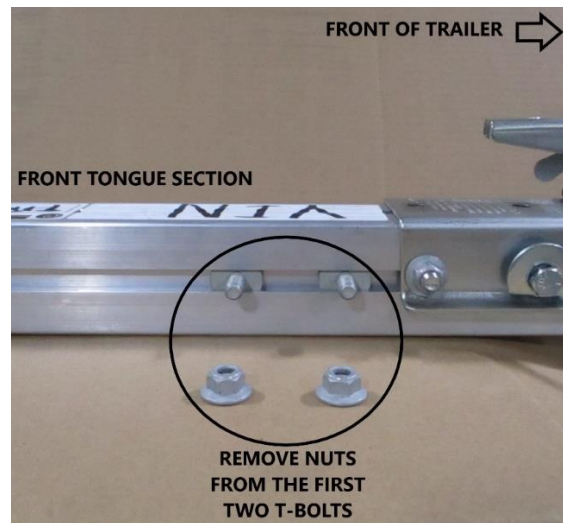

Remove the 2 remaining nuts on both sides of the front tongue section.



Install the bow stand with the roll facing the rear of the trailer and the handles facing the front, as shown. Re-install the nuts and tighten. The final location of the bow stand will be determined when the boat is fitted to the trailer.

## Wheels

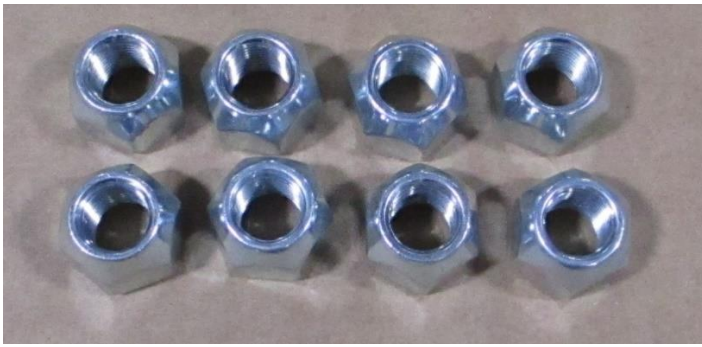

Locate the tires and wheels (**Part V**), and the 8 lug nuts from the hardware bag.



Install the tires and wheels with the valve stems facing out. Install the lug nuts with the tapered side toward the wheel.

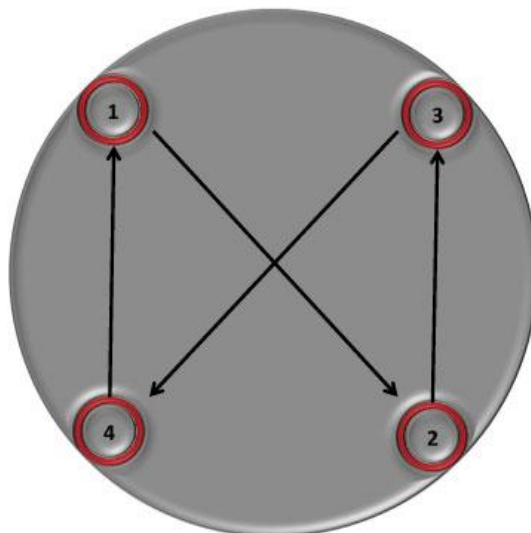

Tighten to 80 foot pounds in a crossing pattern, as shown. Re-tighten after 25 miles.

## Finished Trailer

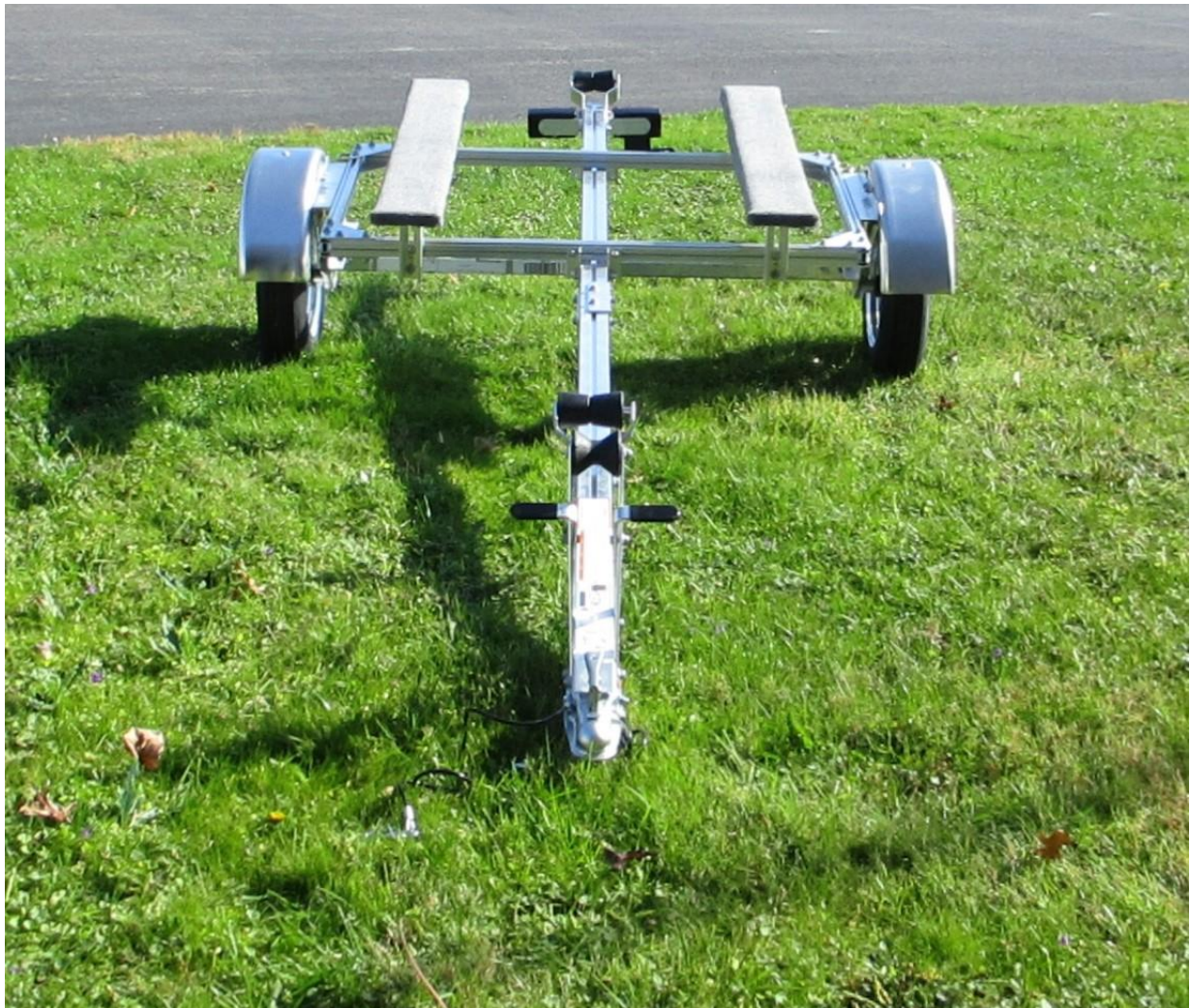

## OPTIONAL STEP FOR SPARE TIRE CARRIER

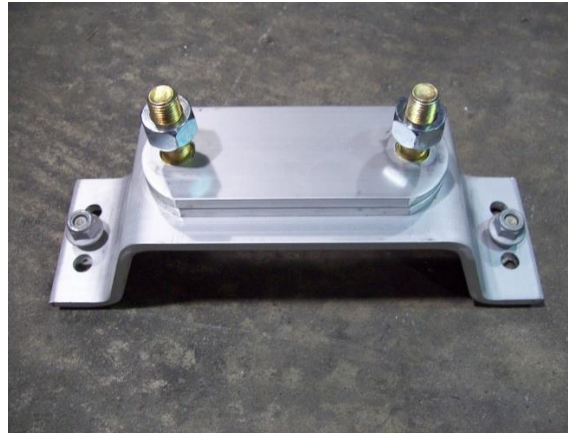

Spare Tire Carrier for SUT Trailers



Loosen the T-bolts and nuts on the spare tire carrier. Insert into the underside of the front tongue section, at the rear. Once the T-bolts are in the channel, slide it toward the coupler.

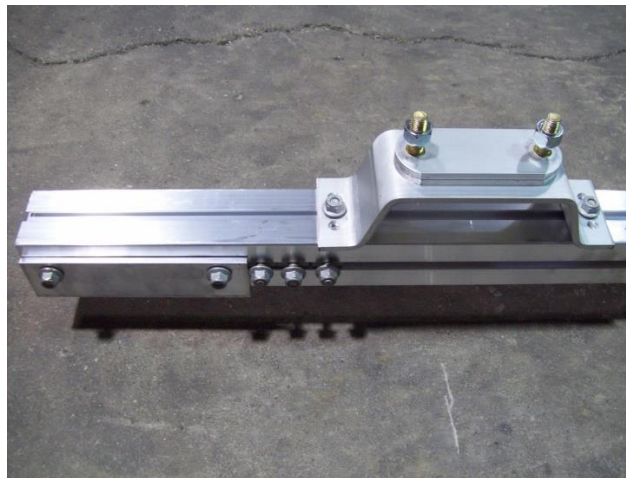

**FRONT OF TRAILER →**

Position the carrier about 18" away from the rear of the front tongue section, then tighten nuts.